



ROSINA Users Manual

Issue 4

Authorised for the Principal Investigator:

.....
Kathrin Altwegg, ROSINA Principal Investigator

Approved by :

.....
P. Ferri, ESOC



Table of Content

1	<i>General Description: Rosetta Orbiter Spectrometer for Ion and Neutral Analysis</i>	
	<i>ROSINA</i>	6
1.1.	Scientific Objectives	6
1.1.1	Scientific Goals	7
1.1.2	Scientific Closure	10
1.2	Experiment Overview	12
1.2.1	DFMS	12
1.2.2	RTOF	26
1.2.3	COPS	42
1.2.4	DPU.....	45
2	<i>Experiment Configuration</i>	47
2.1	Physical	47
2.1.1	Mechanisms Concept	47
2.1.2	Mechanical Interface	48
2.2	Electrical	60
2.2.1	General	60
2.2.2	Power Distribution and Redundancy Scheme	60
2.2.3	Experiment Power Requirements	62
2.2.4	PYROTECHNIC INTERFACE REQUIREMENTS	66
2.2.5	Thermal Interfaces	70
2.2.6	OBDH INTERFACE REQUIREMENTS.....	73
2.3	Software	79
2.3.1	Software Concept and Functional Requirements	79
2.4	Budgets	87
2.4.1	Mass and Power	87
2.4.2	Data Rates / DMS Resource Requirements	87
2.4.3	Thermal Budget.....	90
3	<i>Experiment Operations</i>	92
3.1	ROSINA FM Operations Manual	92
3.1.1	Operating principles	92
3.1.2	General	93
3.1.3	Safety aspects / HV	93
3.1.4	Cleanliness / Purging / Pumping.....	94
3.1.5	Thermal H/W	95
3.1.6	Operations	95
3.2	Operations Plan	96
3.2.1	Ground Test Plan	96
3.2.2	Commissioning Phase near Earth (LEO)	96
3.2.3	Instrument check-out and inflight calibration	96



3.2.4	Flight Operations plans Mission Phase.....	97
3.2.5	Interferences.....	99
3.2.6	Operational constraints	99
3.3	Failure detection and recovery strategy.....	99
4	Mode Descriptions.....	101
4.1	Mode Transition Table.....	101
4.2	Detailed Mode Description.....	102
4.2.1	Instrument modes.....	102
4.2.2	DPU Modes:.....	104
4.2.3	DFMS:.....	105
4.2.4	RTOF:.....	109
4.2.5	COPS Operational modes:.....	113
5	Operational procedures.....	115
5.1	On-board control procedures	115
5.1.1	On-Board Control Procedures.....	115
5.1.2	On-Board Monitoring Requirements	115
5.1.3	Information Distribution Requirements.....	116
5.2	Flight Control procedures.....	117
6	Data Operations Handbook.....	118
6.1	Telecommand Function Definitions	118
6.2	Telemetry Packet Definitions.....	118
6.2.1	DPU – S/C HousekeepingPackets	118
6.2.2	Science Data Sets.....	118
6.2.3	Science Packet Definitions	119
6.2.4	Science Housekeeping Definitions	120
6.3	Event Packet Definitions	128
6.3.1	Packet Types and EIDs	128
6.3.2	Normal Event Packet Definitions, Sub Type 1	128
6.3.3	Anomalous Event Packet Definitions, Sub Type 2.....	133
6.3.4	Ground Action Event Packet Definitions, Sub Type 3	135
6.3.5	On-board Action Event Packet Definitions, Sub Type 4.....	135
6.4	Context File Definition	136



Change Record

Issue	Date	Change	Responsible
Draft	October 2000	Initial Issue	Altwegg
Issue 1	December 2000	Adapted to FM	Altwegg
Issue 1, rev. 1	July 2001	Flight ops as separate document	Altwegg
Issue 1, rev 2	July 2001	DPU commands and housekeeping as separate documents in the annex A and B	Altwegg
Issue 2, rev.0	February 2002	RTOF WCS replacement by ETS-L, DPU commands and housekeeping, flight operations: planet flyby's and cruise phase	Altwegg
Issue 2, rev.1	March, 2002	Added DPU event packets, and reference to CRP	Altwegg
Issue 2,rev2	July, 2002	Changes according to EFOR, include operations manual, temp. limits. New organisation with annexes A-F	
Issue 3, rev 0	December, 2002	Finalization of FOP, instrument mode manuals	Altwegg
Issue 3, rev 1	March 06	Update of annexes B, C, deletion of ground test procedures, consolidation after launch	Altwegg
Issue 4, rev 0	January 2011	Update of annexes D	Altwegg

List of reference documents

RD1 RO-EST-RS-3013, Issue1,Rev0 EID-B



List of Annexes

A			Ground test Procedures
			Deleted after launch
B	RO-ROS-MAN-1015, 4-2a	13.05.04	Flight operations procedures
C	RO-ROS-MAN-1023, 1.1	21.03.2006	ROSINA Contingency Recovery Procedure
D			Instrument Modes
D1	RO-ROS-MAN-1010, 6	01/.2011	DFMS Instrument Operation Modes
D2	RO-ROS-MAN-1011, 6	01/2011	RTOF Instrument Operation Modes
D3	RO-ROS-MAN-1019, 1.7	01/112011	COPS Instrument Operation Modes
D4	Hk-monitoring.xls	19.12.2005	HK-Monitoring
E	ROS-TUB-MA-08, 1.0	19.04.2002	ROSINA FS SW operations Manual
F			Operations Handbook
F1	ROS-TUB-SP-04/2.4	19.04.2002	S/C – DPU Command Packets
F2	ROS-TUB-SP-02/3.0	19.04.2002	DPU – S/C Housekeeping Packets
F3	ROS-TUB-MA-07/1.8	29.07.2002	S/C – DPU Command description
F4	ROS-TUB-SP-05/2.3	04.07.2001	DPU – S/C Event Packets
F5	ROS-TUB-MA-05/2.3	05.09.2001	ROSINA Mode Change Commands
G			EGSE
G1	ROS-TUB-ID-07/2.1	04.04.2002	Configuration Status
G2	ROS-TUB-MA-03/3.1	04.04.2002	User Manual
G3	RO-ROS_Man_1007, 1.1	16.08.2000	EGSE Startup Manual



1 General Description: Rosetta Orbiter Spectrometer for Ion and Neutral Analysis ROSINA

The Rosetta Orbiter Spectrometer for Ion and Neutral Analysis (ROSINA) will answer outstanding questions concerning the main objectives of the Rosetta mission. To accomplish the very demanding objectives, ROSINA will have unprecedented capabilities, including. very wide mass range from 1 amu to >300 amu; very high mass resolution (ability to resolve CO from N₂ and ¹³C from ¹²CH); very wide dynamic range and high sensitivity; the ability to determine cometary gas, velocities, and temperature. The necessities for these capabilities stems from the requirements to monitor the comet during the whole mission through all different phases of activities. Two sensors are needed to accomplish the science objectives.

1.1. Scientific Objectives

Comets are believed to be the most pristine bodies in the solar system. They were created 4.6 billion years ago far away from the sun and have stayed for most of the time of their existence far outside of Pluto. They are small enough to have experienced almost no internal heating. They therefore present a reservoir of well-preserved material from the time of the creation of the solar system. They can present clues to the origin of the solar system material and to the processes which led from the solar nebula to the formation of planets. Some of the material present in comets can even be traced back to the dark molecular cloud from which our solar system emerged (e.g. Irvine, 1999). In contrast to meteorites, the other primitive material available for investigations, comets have maintained the volatile part of the solar nebula.

Several interesting questions on the history of the solar system materials can therefore only be answered by studying comets, and in particular by studying the composition of the volatile material which is the main goal of the ROSINA instrument. Below is a list of measurements still to be made and the associated topics that can benefit from it. The list is certainly incomplete and will evolve with time.

Elemental abundances:

- Nitrogen abundance: Physical and chemical conditions during comet formation;
- Noble gases: Processing of comets

Isotopic abundances:

- D/H in heavy organic molecules: Origin of material
- Other isotopes in different molecules (C, O etc.): Origin of material

Molecular abundances:

- Heavy organic molecules: Origin of material; processing of material prior to incorporation in comets



- Reduced vs. oxidized molecules: Chemical and physical conditions during molecule formation; origin of material
- Series of molecules, e.g. C_nH_m : Origin of material; processing of material prior to incorporation in comets
- O_2 , O_3 : Origin of terrestrial oxygen
- Radicals : Physical and chemical conditions during comet formation; processing of comets

Physical and chemical processes:

- Extended Sources: Composition of dust in the coma;
- Molecular abundances as function of heliospheric distance: Nucleus composition, and processing of nucleus
- Molecular abundance differences in jets: Homogeneity of nucleus composition; spatial and temporal differences
- Abundance differences between Oort cloud comets and Kuiper belt comets: Physical and chemical conditions in the different comet forming regions; chemistry in the solar nebula and sub-nebulae

1.1.1 Scientific Goals

As part of the core payload of the Rosetta mission, the Rosetta Orbiter Spectrometer for Ion and Neutral Analysis (ROSINA) will answer outstanding questions concerning the main objectives of the mission. The primary measurement objective of the spectrometer is:

- To determine the elemental, isotopic and molecular composition of the atmospheres and ionospheres of comets as well as the temperature and bulk velocity of the gas and the homogenous and inhomogeneous reactions of gas and ions in the dusty cometary atmosphere and ionosphere.

In determining the composition of the atmospheres and ionospheres of comets, the following prime scientific objectives, also defined by the Rosetta Science Definition Team will be achieved:

- Determination of the global molecular, elemental, and isotopic composition and the physical, chemical and morphological character of the cometary nucleus.
- Determination of the processes by which the dusty cometary atmosphere and ionosphere are formed and to characterize their dynamics as a function of time, heliocentric and cometocentric position.
- Investigation of the origin of comets, the relationship between cometary and interstellar material and the implications for the origin of the solar system.
- Investigation of possible asteroid outgassing and establish what relationships exist between comets and asteroids.



To accomplish these very demanding objectives, ROSINA must have unprecedented capabilities, including:

- 1) Very wide mass range from 1 amu (Hydrogen) to >300 amu (organic molecules).
- 2) Very high mass resolution (ability to resolve CO from N₂ and ¹³C from ¹²CH).
- 3) Very wide dynamic range and high sensitivity to accommodate very large differences in ion and neutral gas concentrations and large changes in the ion and gas flux as the comet changes activity between aphelion and perihelion.
- 4) The ability to determine the outflowing cometary gas flow velocities.

The necessity for the unusual high capabilities of this experiment stems from the fact that it is one of the key instruments which is able to give meaningful data during the whole mission and thus by monitoring and characterizing the different phases of comet activity from apogee through perigee will lead to a full understanding of cometary behavior. Correlated studies with optical observations, with, for example, the dust instruments, the magnetometer and the surface science package further augment the scientific return of the ROSINA instrument.

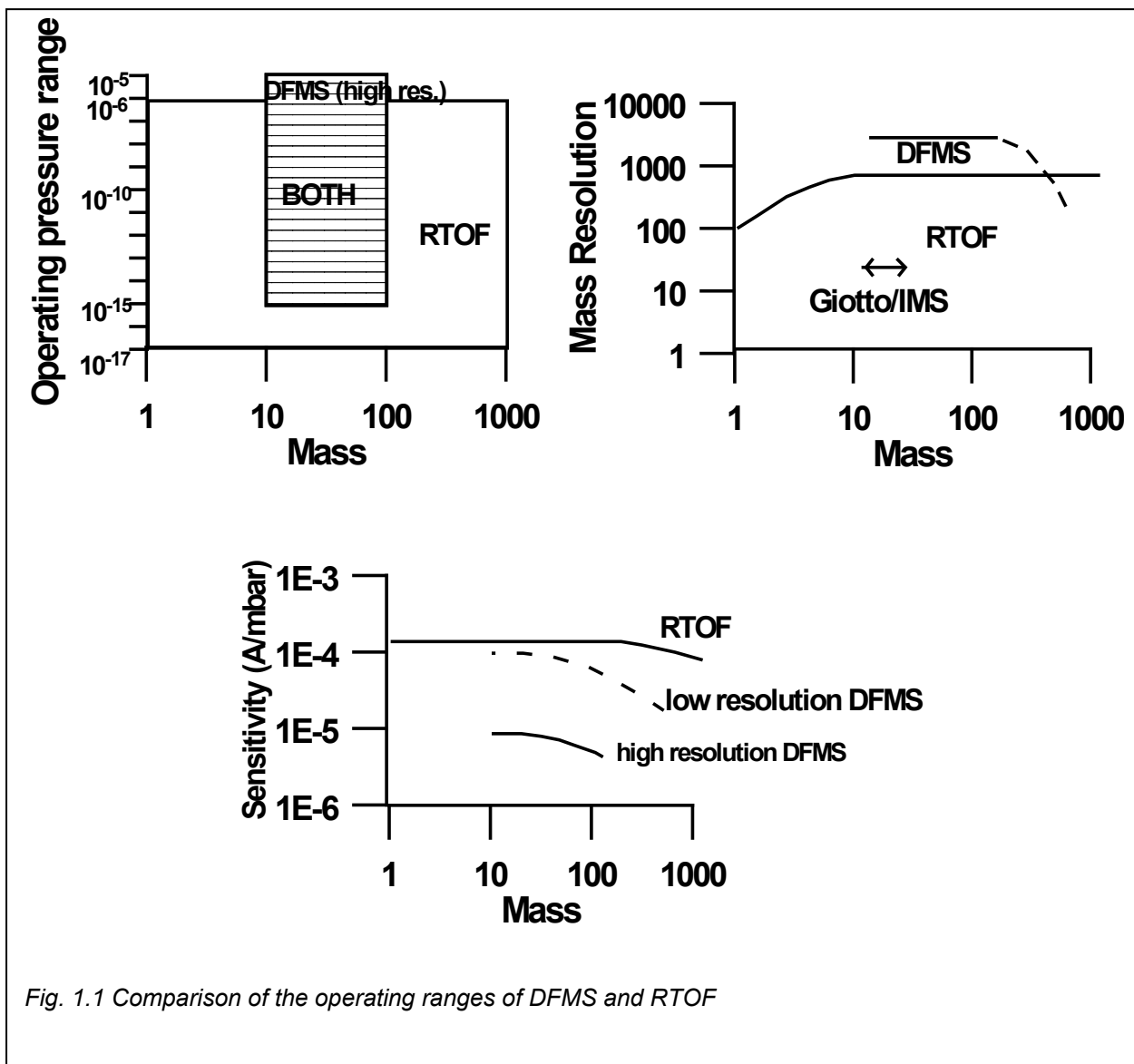

Fig. 1.1 Comparison of the operating ranges of DFMS and RTOF



INSTRUMENT REQUIREMENTS

Table 1 lists the science objectives and the instrument requirements necessary to achieve them. The necessary performance of ROSINA is summarized in table 2 and the comparison of operating ranges of the two mass analyzers is given in fig. 1.1.

The requirements listed in Table 1 are unprecedented in space mass spectrometry. So far, no single instrument is able to fulfill all of these requirements. We have therefore adopted a three-sensor approach: each sensor is optimized for part of the scientific objectives while at the same time complementing the other sensors. In view of the very long mission duration they also provide the necessary redundancy.

Sensor I (DFMS) is a double focusing magnetic mass spectrometer with a mass range 1- 100 amu and a mass resolution of 3000 at 1 % peak height. Th sensor is optimized for very high mass resolution and large dynamic range.

Sensor II (RTOF) is a reflectron type time of flight mass spectrometer with a mass range 1->300 amu and a high sensitivity. The mass resolution is better than 500 at 1 % peak height. This sensor is optimized for high sensitivity over a very broad mass range.

Sensor III (COPS) consists of two pressure gauges providing density and velocity measurements of the cometary gas.

Table 1.1 Science objectives and measurement requirements for ROSINA

Scientific Objectives	Associated critical measurements	Measurement requirements
Determine elemental abundances in the gas	Separate CO from N ₂	Mass resolution >2500 at 1 % of peak height at mass 28 amu
Determine molecular composition of volatiles	Measure and separate heavy hydrocarbons (neutrals and ions) up to mass 300 amu	Mass range 1-300 amu with a resolution of >300 at 1 %; Sensitivity >10 ⁻³ A/Torr
Determine isotopic composition of volatiles	Separate ¹² CH and ¹³ C. Measure HDO, DCN and other deuterated neutrals and ions	Mass resolution >3000 at 1 % peak height, relative accuracy 1 %, absolute accuracy 10 %
Study the development of the cometary activity	Measure the composition (water and minor constituents) between 3.5 AU (gas production rate 10 ²⁴ s ⁻¹) and perihelion (10 ²⁹ s ⁻¹)	Mass range 1-300 amu, dynamic range 10 ⁸



Study the coma chemistry and test existing models	Measure ions and molecules in the mass range 1-300 amu and their velocity and temperature	Mass range for ions and neutrals 1- >300 amu, dynamic range 10^8 sensitivity $>10^{-3}$ A/mbar
Study the gas dynamics and the interaction with the dust	Measurement of the bulk velocity and temperature of the gas	Bulk velocity corresponding to $E=0.02$ eV $\pm 10\%$, temperature = 0.01 eV $\pm 20\%$
Characterization of the nucleus	Characterization of outbursts and jets of limited angular extent	2° Narrow field of view, time resolution = 1 minute
Characterization of asteroids	Detect asteroid exosphere or determine upper limit	Extreme sensitivity for H ₂ O, CO, and CO ₂

Table 1.2: ROSINA Performance

Component	Mass Range [amu]	Mass Resolution $m/\Delta m$ (at 1%)	Sensitivity Gas [A/mbar] (1)	Ion (2)	Dynamic Range (3)	Pressure Range [mbar] (4)	FOV	Highest time resolution for full spectrum
DFMS (5)	12-100	3000	10^{-5}	10^4	10^{10}	$10^{-5} - 10^{-15}$	20° x 20° 2° x 2° (6)	120 s
RTOF	1- >300	>500	10^{-4}	10^3	$10^6/10^8$	$10^{-6} - 10^{-17}$	5° x 20°	4 s / 5 min.
COPS			3×10^{-2}		10^6			10 sec.

- (1) 1×10^{-3} A/mbar corresponds to 0.2 counts/s if density is 1 cm^{-3} . Emission current of the ion source at 10 μA , can be increased (up to a factor of 5) or decreased
- (2) Counts per second for cometary ion density of 1 cm^{-3}
- (3) Ratio of highest to lowest peak in one measurement cycle
- (4) Total measurement range
- (5) High resolution mode
- (6) Narrow field of view entrance

1.1.2 Scientific Closure

Table 3 shows the data products from the ROSINA investigation and the corresponding scientific objectives that will be addressed using these data products. In addition to the specific science objectives of ROSINA listed in the table, the data products will provide key information for additional science objectives of other Rosetta orbiter and lander instruments. Collaboration between the ROSINA



investigation and other orbiter and lander investigations will greatly enhance the scientific results in several key areas including: dust-gas interaction, gas-plasma interaction, causes of cometary activity, and compositional differences within the nucleus.

Table 1.3. ROSINA sensors, data products and science objectives. .

Sensor	Data Product	Science Objective
DFMS/ RTOF	- High Resolution and High Sensitivity Mass Spectra	Origins of Comets Origins of organic material in comets
	- Heliocentric/temporal dependence	Onset of cometary activity, composition changes in the coma
	- Cometocentric dependence	Coma chemistry, gas-dust interaction Causes of cometary activity,
	- Detailed mapping of active and quiescent regions	Composition of the Nucleus compositional differences within the nucleus
COPS	Neutral Pressures, Velocities, Temperatures	Coma gas-dust dynamics

A complete understanding of the dust-gas interaction will require collaboration between ROSINA and the dust investigation. The comet produces approximately equal concentrations of gas and dust and there is a strong indication that this combination is responsible for extended sources such as CO in comet Halley. Extended observations of the comet by both ROSINA and the dust experiments will be exploited in a search for other extended gas sources and a complete characterization of the known extended sources and their origin within the dusty atmosphere.

Similarly, an understanding of the gas-plasma interaction will require collaboration between ROSINA and the plasma experiment. Basic quantities such as the gas production rate of the comet obtained from ROSINA will be important elements in the understanding of the plasma observations. Likewise, the plasma flow velocity, the electron temperature and the magnetic field will be important quantities for determining and checking the location of the contact surface near the comet when it is close to the sun. Low energy ion flow inside the contact surface is significantly affected by the presence of this barrier and its location will be important in interpreting the ROSINA ion observations.

A complete understanding of the causes of cometary activity and compositional differences within the nucleus will require collaboration between ROSINA and several orbiter and lander investigations. One important aspect to be investigated is



the composition of volatiles measured by ROSINA and the composition of non-volatiles surface components measured by the lander. A cross-check of the relative composition of these two cometary components is required to completely account for cometary composition and to understand how (or if) the cometary coma differs from the evacuated material in the mantle. This combination of orbiter and lander composition measurements will be key in resolving the question of the ultimate fate of comets in the solar system.

Causes of cometary activity and compositional differences within the nucleus will also be investigated through a collaboration between ROSINA and other orbiter investigations. One important collaboration will be the coordinated mapping of cometary active regions with ROSINA, the camera investigations and the dust investigation. Possible compositional differences of the active regions will be measured directly with the narrow field of view part of the ROSINA DFMS. In coordination with camera and dust observations, these regions will be localized and identified. Possible compositional differences of each of these regions will be investigated periodically during the mission to determine if gas from these regions change with increasing cometary activity.

1.2 Experiment Overview

1.2.1 DFMS

1.2.1.1 Design Goals

The double focusing mass spectrometer is a state of the art high resolution Matauch - Herzog mass spectrometer (resolution $m/\Delta m > 3000$ at 1% peak height) with a high dynamic range and a good sensitivity. It is based on well-proven design concepts, which were optimized for mass resolution and dynamic range using modern methods for calculating ion optical properties. The main design goals are given in table 1.2.

The DFMS has two basic operation modes: a gas mode for analyzing cometary gases and an ion mode for measuring cometary ions. Switching between the gas and ion modes requires changing only a few potentials in the ion source and suppression of the electron emission that is used to ionize the gas. All other operations are identical for the two modes.

1.2.1.2 Ion Optics

Ion source: The design of the ion source is based on the electron bombardment source used in modern laboratory rare gas mass spectrometers. This source combines high sensitivity (10^{-3} A/mbar) with good linearity over a very wide gas pressure range (from several 10^{-5} mbar to below 10^{-14} mbar), small energy dispersion and low background.

The source has two viewing directions with different field of views (FOV). The one

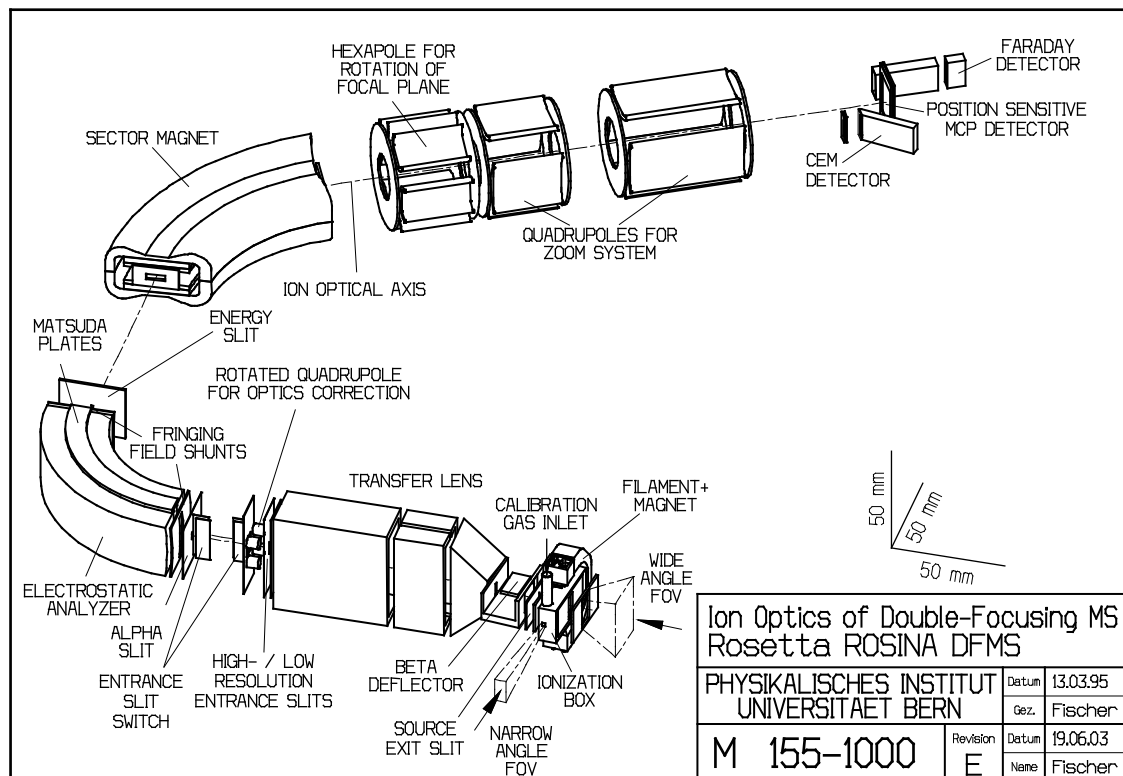

Fig. 1.2: DFMS ion optical principle

parallel to the source axis has a wide FOV of $\pm 20^\circ$, the one orthogonal to it a narrow FOV of $\pm 2^\circ$. For most of the measurements the wide FOV will be used, allowing cometary gas with wide angular spread in the flow direction to enter the ionization region. The narrow FOV will be used for determining the exact flow direction of the cometary gases. The axis of the wide FOV will normally be directed towards the nucleus and hence be parallel to the axis of the cameras.

The FOV's are determined by a set of electrodes upstream of the ionization region. In Figure 1.2 only those for the wide FOV are shown. Suitable potentials applied to these electrodes prevent the entry of low energy ions into the DFMS in the gas mode. Cometary ions with higher energies (>60 eV) cannot pass through the analyzer and it is not necessary to prevent their entry into the ion source. In the ion mode the potentials on these electrodes are changed to attract the cometary ions even in case of positive charging of the S/C and to focus them into the gas ionization region of the source. A coarse meshed grid on a negative potential surrounding the ion source area to a distance of 15 cm is used to augment the ion attraction.

The instrument degassing could lead to serious interference while measuring the cometary gases. To keep the interference as low as possible the whole ion source region is built to UHV standards and degassed before launch and also during flight. Since the narrow analyzer entrance slit has a very low vacuum conductance (only connection between the source and analyzer regions) outgassing from internal sensor parts is efficiently suppressed.

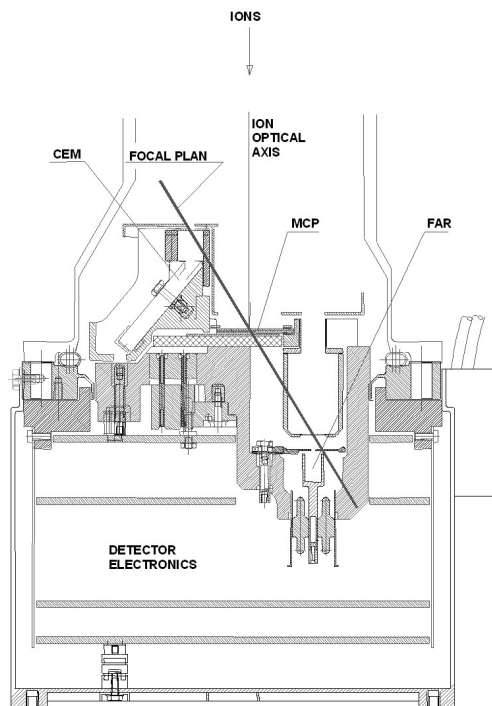

Fig. 1.3 Section of the detector package in the plane of symmetry with the associated RDP electronics boards. FC: Faraday Cup, MCP: Multichannelplate with LEDA 512, CEM: Channeltron

The cometary gases entering the source are ionized with an electron beam parallel to the slit direction. A weak magnetic field (0.02T) is used to guide the electrons. Two filaments are provided to give redundancy. The electron energy can be varied between about 10 and 90 eV. At higher electron energies the ionization cross section is maximal and hence the instrument sensitivity optimal. At low electron energies the cross section is considerably smaller but there is much less fragmentation of the more complex molecules. This can be used to facilitate the identification of unknown species. The ion source can be operated with electron currents of 2 μA , 20 μA or 200 μA to provide three sensitivity levels which differ by a factor of 10. A gas pipette delivering calibrated amounts of a noble gas mixture into the ionization region will be used for in-flight tests and calibration of the DFMS.

For mass scanning it is necessary to vary the energy of the ions. To minimize the resulting mass and sensitivity

discrimination the ion source is operated at a fixed acceleration potential of 3 kV. After the first focus (line width typical 150 μm) a transfer lens is used to accelerate/decelerate and focus the ions onto the entrance slit of the analyzer section. There are two entrance slits, a narrow slit (14 μm) and a wide slit (200 μm). The ion beam can be guided through the narrow slit in the high resolution mode or through the wide slit in the low resolution mode by electrostatic deflection. The axis of the transfer lens is tilted by 6° relative to the ion source axis. This shields the narrow entrance slit of the analyzer from cometary dust particles.

The final ion energy is established in the transfer section of the ion source. To pass through the analyzer with its fixed magnetic field the ion energy must be changed from 6 keV at mass 12 amu to 720 eV at 100 amu. Thus, the 3 keV ions from the source are either accelerated or decelerated in this section and at the same time focused on the entrance slit of the analyzer.

The mass analyser: The following key requirements for the Rosetta DFMS which had to be considered in the selection of the analyzer geometry were:

- Mass resolution $m/\Delta m > 3000$ for mass range 12 to 100 amu/q at the 1 % peak level
- Good energy focusing properties to allow $\Delta E/E$ of up to 1%, important if lower ion energies are used.
- High mass dispersion to allow the use of a position-sensitive focal plane detector.



- A large free viewing angle (preferably 2π) for the ion source acceptance.
- A small overall size with a radius of curvature in the magnet not more than 10 cm.

The resulting optimal field geometry is a combination of a 90° toroidal electrostatic analyzer (ESA) with a 60° sector magnet for momentum analyses (see Figure 1.2). High mass dispersion can be achieved by using an electrostatic zoom lens system. At the high mass resolutions the detector and focal plane coincide only at one mass number. High resolution can thus only be obtained for the mass multiplets at one mass number and the mass lines from neighboring mass numbers will show less mass resolution. To obtain a full high resolution mass spectrum from 12 to 100 amu/q it is thus necessary to record a mass spectrum at each integer mass number. The analyzer can also be operated in a low resolution mode which allows the simultaneous recording of several mass lines on the position-sensitive detector with a resolution of $m/\Delta m$ of several hundred. Neighboring integer mass numbers are well separated at this mass resolution. In this mode the zoom system is used to rotate the alpha focal plane into the plane of the position-sensitive detector.

Ion detectors: The instrument has three independent ion detectors (see Figure 1.2).

Design considerations for detectors:

Within a mass range which is controlled by the setting of the ion optics, ions exiting from the DFMS are focused on a focal plane and therefore provide an instantaneous one-dimensional image of the mass spectrum of the comet ionised or neutral gas. The detector package which has been designed specifically for the DFMS has to meet to a number of requirements which may be briefly summarized as follows:

- In the central part of the ion beam exiting the spectrometer, the detector must provide an image of the focal plane with a resolution corresponding to the highest mass resolving capability of the spectrometer. This corresponds to an equivalent pixel size of 25μ along the direction of the focal plane over a length of about 1.25 cm.
- The overall dynamical range of the detector has to comply with the anticipated extremely large variations of ion fluxes at the exit of the spectrometer. These arise predominantly from the variations of nucleus outgassing as a function of comet activity, from the large differences in density between major constituents, such as water and minor constituents or isotopes, and also from the varying sensitivity of the instrument as a function of its mode of operation (ion and neutral mode, low or high mass resolution, etc...). The necessary overall dynamical range has been estimated to about 10 orders of magnitude.
- The instantaneous dynamical range has to cope with the temporal variations of the cometary gas during a single measurement and with the differences in ion fluxes impinging at various locations on the detector front face for the whole range of masses simultaneously measured. Owing to the expected quite slow temporal variations of the cometary atmosphere in the vicinity of the orbiter and to the fast measuring rate allowed by the detector, which can be made as fast as 100 measurements per second, the second constraint is more important. From the anticipated chemical



and isotopic composition of the cometary gas an instantaneous dynamical range of $4 \cdot 10^3$ was taken as the design objective.

The detector package has to warrant the necessary accuracy of the measurements up to the end of a long lived mission of more than 10 years. Owing to the anticipated gain variations of MCP's or Channeltrons, it is thus necessary for the detector package to provide an absolute calibration by measuring directly the ion fluxes in the focal plane that correspond to the most abundant species such as H_2O or the water group ions. This led to include a Faraday cup in parallel to the main imaging, MCP based, detector and to have modes wherein the water peak can be moved alternately from the imaging detector to the Faraday cup.

Finally, reliability considerations that are of paramount importance for this long and certainly innovative mission have led to two last specifications. First, it was decided to equip the detector package with a second detector allowing measurements of the mass spectrum with a resolution and a dynamical range identical to those provided by a single pixel of the imaging detector. This was achieved by using a Channeltron (CEM) with a slit in front of the entrance to insure the necessary resolution. The second specification is related to the imaging detector itself; the large height of the mass focal lines in the focal plane has allowed to split the collector of the imaging detector into two halves along the focal plane axis and thus to use an ASIC circuit with two separate and redundant collectors and electronics, thus ensuring a total redundancy of this critical part of the instrument.

Description of the detector package: The detector package is shown in figure 1.3 which represents a section along the plane of symmetry. The development of this package was the result of a joint effort by teams from BIRA-IASB, CETP, IMEC for the ASIC electronics realization and LMATC for part of the electronics. The broken red line indicates the location of the theoretical focal plane of the spectrometer. The main imaging detector is located in the center of the detector package, as indicated by the position of the MCP. We anticipate using a stack of 2 Chevron MCP's with a rectangular form adapted to the geometry of the focal plane, a pore size of either 6 or 12μ and a total gain at saturation of about 10^6 . In order to keep the maximum resolution the MCP front face should have been located exactly coincident with the focal plane. However, the energy of the ions impinging on the front face of the MCP must be larger than about 0.5 keV in order to allow for a large enough MCP detection efficiency. A maximum of efficiency for ion species that are expected in the comet atmosphere is reached at about 3 keV. In order to prevent large perturbations of the ion trajectories which would totally deteriorate the focusing properties of the spectrometer the MCP must be approximately perpendicular to the average ion trajectories and positioned as shown in figure 1.3. Extensive numerical modeling has shown that with such a geometry the global resolution of the instrument is adequate and reaches the specified value.

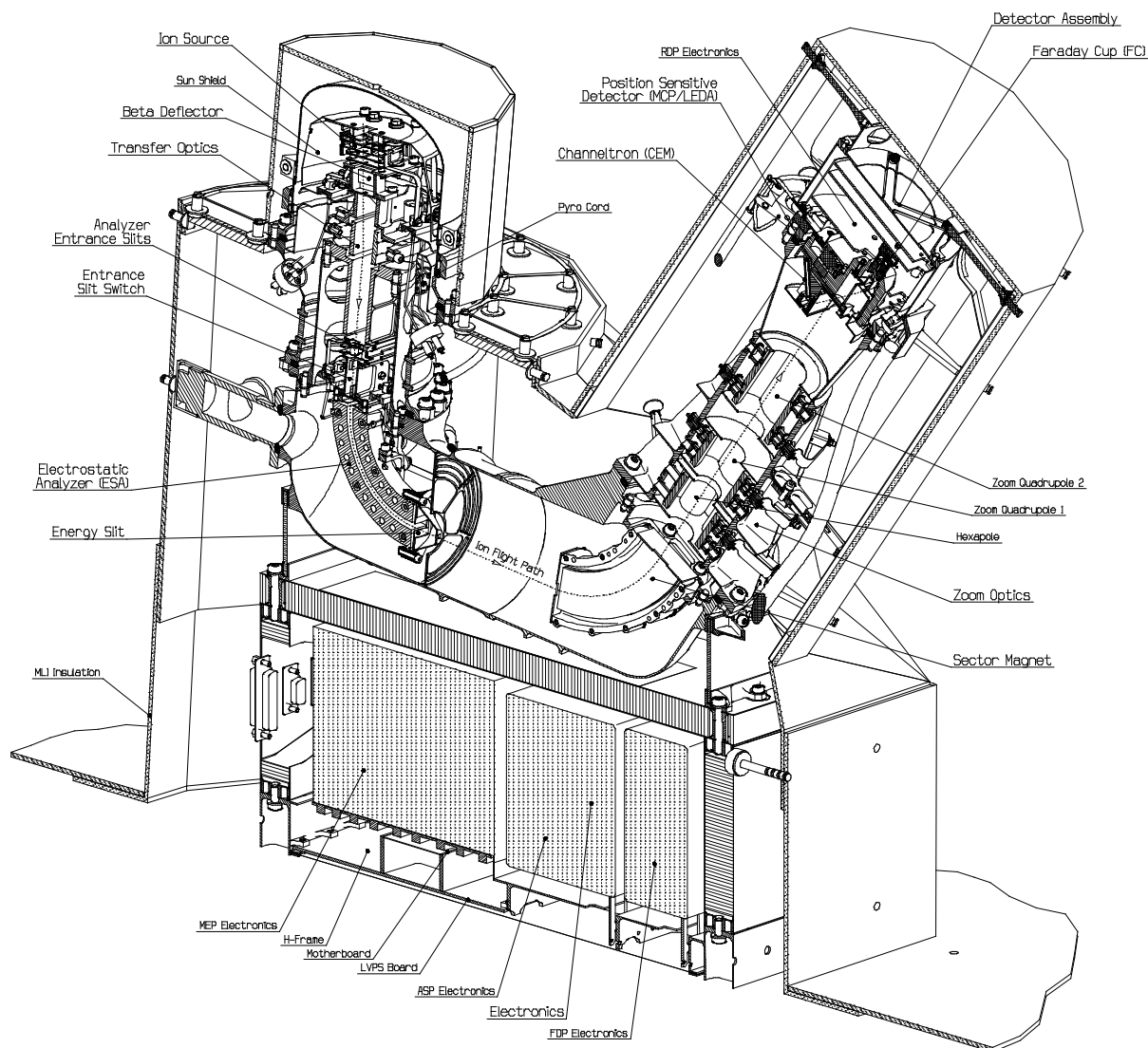

Fig. 1.4: 3-d engineering model of DFMS

The CEM is located at the upper left part of the detector package. A 20 μ wide slit positioned ~ 1 cm in front of it and coincident with the location of the end of the focal plane, provides the required resolution. At the same time it prevents the high voltage on the CEM entrance to leak and affect ion trajectories in the drift space before the focal plane. The CEM may be operated both in a counting and an analogue mode. The Faraday cup (FC) can be seen on the right end of the figure with a 0.35 mm slit in front of the cup and coincident with the right end of the focal plane. It provides the needed medium resolution measurements current on the water peak with a current range from 10^{-14} to 10^{-8} A.

1.2.1.3 Mechanical / Structure

Fig. 1.4 shows a three dimensional picture of the DFMS sensor. The main components are the primary structure, which contains the ion optics, the secondary structure that houses the electronics, the cover opening mechanism and the in-flight

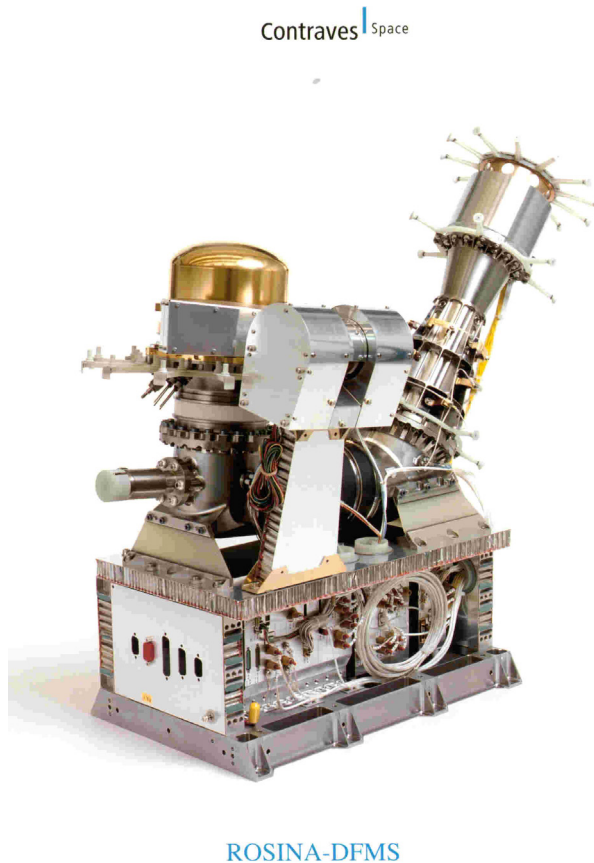

Fig. 1.5: DFMS Electrical Qualification model

calibration system.

The primary structure is made from titanium and ceramics in order to be compatible with the ultrahigh vacuum requirements. It can be baked out up to 120 °C, or up to 250 °C for the ion source. The banana shaped tube contains all ion optical elements. The mechanical requirements with respect to tolerances are very high. The toroidal surfaces of the electrostatic analyzer have to be within $\pm 2 \mu\text{m}$ of the ideal surface. All the ion optical elements are co aligned with an accuracy of a few μm . All along the ion trajectories the surfaces are gold plated or gold sputtered in order to get uniform electrical fields. The primary structure is electrically and thermally isolated from the secondary structure. The main part is at high voltage of up to 6 kV during operation whereas the entrance part with the ion source is at a few volts relative to the spacecraft. A ceramic ring guarantees the electrical insulation between the two parts. In order to maintain the detectors within the

given temperature limits of -20 to +30 °C the MLI surrounding the detector part contains a non-operational heater as well as a radiator.

The primary structure will be baked out and then sealed by a cover to minimize contamination. It will be evacuated through a pump-off valve. The vacuum keeping requirements ask for a pressure of $<10^{-5}$ mbar after 1 week without pumping. The cover will only be opened in space by a pyrotechnical device. After the initial opening it can be reclosed and will be tight with respect to the molecular flow conditions in space. It is intended to close the cover during thruster firing and in case of high dust activity near the comet in order to keep the sensor clean. In case of a failure of the cover motor, a pyrotechnical device can disengage the gear of the cover and the cover will then stay in an open position.

The secondary structure is made from aluminum, partly as honeycomb structure. It houses the different electronics pack. The electronics, which is on high voltage, is insulated from the spacecraft ground by BeO – standoffs in order to guarantee at the same time a good electrical insulation as well as a good thermal conductivity. The primary structure is mounted on spring blades made from carbon fiber material on top of the secondary structure. This allows compensation for the different thermal

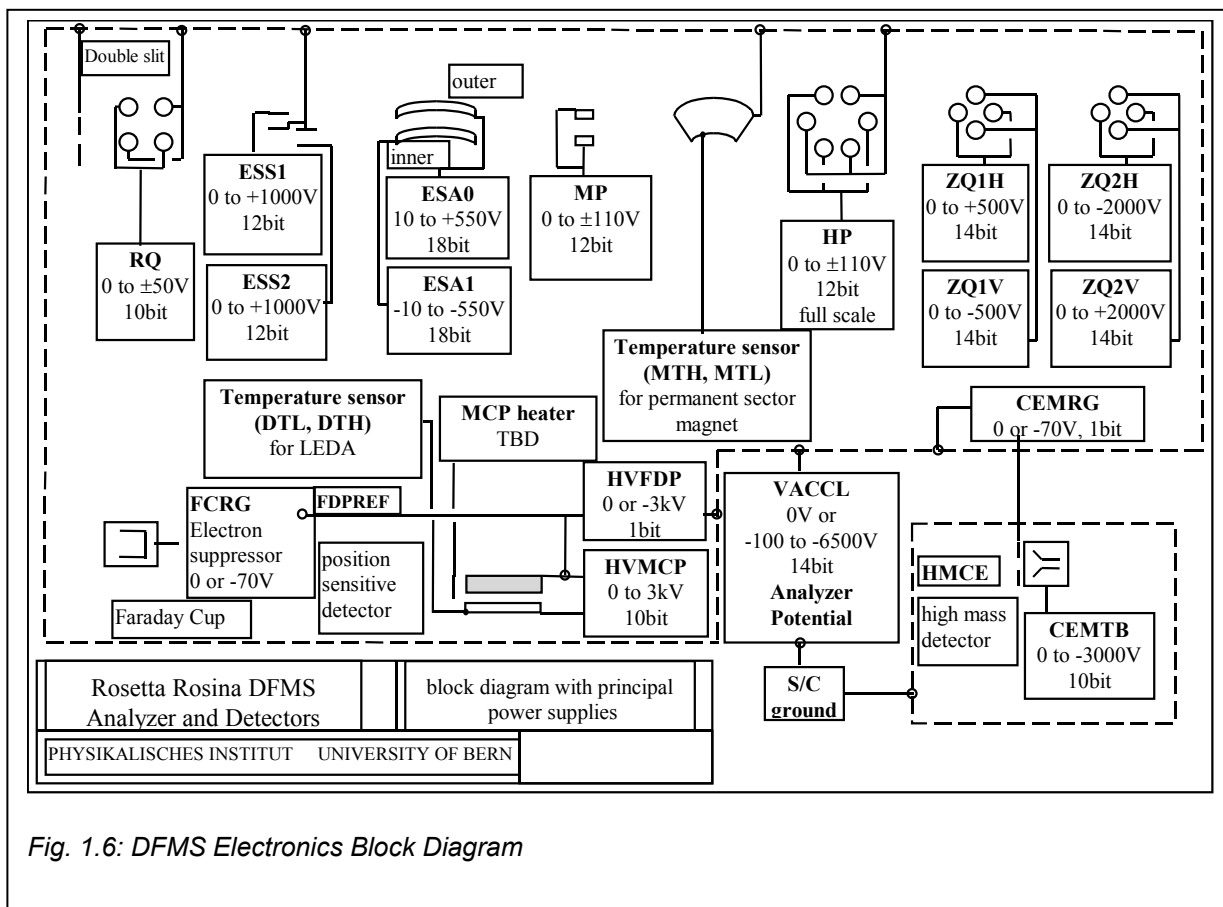

Fig. 1.6: DFMS Electronics Block Diagram

expansion coefficients.

The in-flight calibration system contains two gas containers each containing about 10 cm³ of a noble gas mixture at 1 bar pressure. It is identical to the one used in RTOF. For a detailed description see 1.2.4.

Fig. 1.5 shows the electrical qualification model of DFMS.

1.2.1.4 Electronics

The ROSINA DFMS electronics described here controls provides power and controls the cover mechanism, ion source and gas calibration unit, all elements of the ion optics, and the detectors. All control is provided through an interface with the ROSINA DPU. The ROSINA DPU does actual commanding and acquiring housekeeping and science data so that the DFMS electronics is not required to store data or commands. An overall block diagram is given in fig. 1.6.

A cover that, once the vacuum seal is broken after launch, can be open and closed and placed in intermediate positions protects the ion source. This capability is required to protect the instrument from contamination (for example from very high pressures near the comet) and it provides a shutter, which can be partially closed, blocking the cometary ion and neutral influx. This second purpose will allow in-flight calibration using the calibration unit and also allow determination of the rest gas inside the spectrometer during the comet encounter.

The cover motor and the ion source are on spacecraft ground potential. The motor is controlled by a pre-programmed actel chip which provides the capability to ramp



up the cover motor current at any rate desired, maintain a constant current input to the motor, and ramp down the cover motor current at any rate desired. Sensors on the cover provide the motor controller with the open and close limits. In addition, the motor has hall sensors, which the motor controller uses to count the number of motor revolutions. The position of the cover as a function of the number of revolutions is calibrated prior to launch so that the cover can be placed in any arbitrary position between the open and closed limits.

The ion source contains two filaments (for redundancy), which are powered by the ion source controller. The ion source controller regulates the current to the filaments and also receives housekeeping information on the source filament current and temperature in the vicinity of the filament (see fig. 1.6 for a block diagram). The current limits for the ion source are set prior to electronics integration. Otherwise, the filaments can be commanded to any current level within these limits by the ion source controller. In addition to the low voltage, high current power supply for electron emission, there are 10 other power supplies for the ion source.

Starting at the entrance to the ion source, there is one ion source voltage commandable from 0 to ± 300 V with 12 bits accuracy. This voltage repels ions coming from the comet so that, when it is on and the emission source is on, neutrals from the comet can be analysed without interference from cometary ions or from ions of other origin. Following the ion suppression, two power supplies provide voltages, which keep ions created in the ion source from escaping back through the entrance aperture. Two power supplies provide the ionisation box with potentials, which accelerate the electrons from the filament across the aperture field of view. The newly created ions are extracted from the ionisation region, accelerated to high

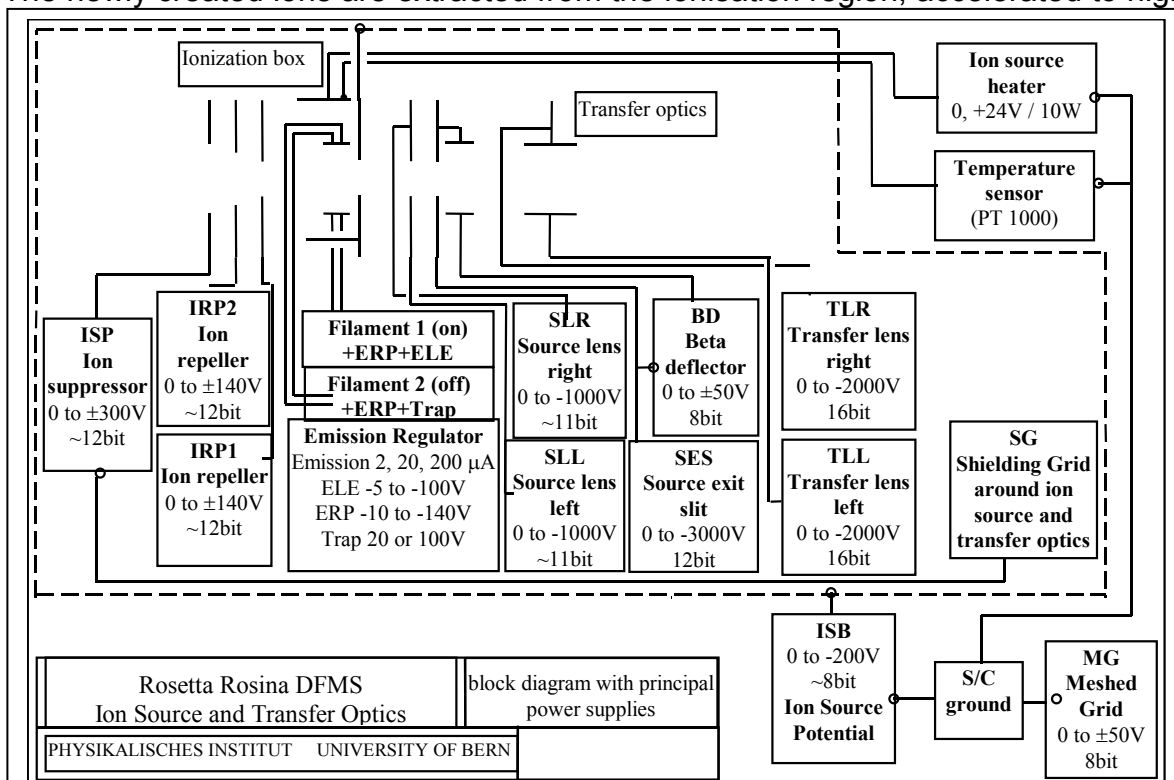

Fig. 1.7: DFMS Ion source and transfer optics block diagram



voltage, and passed through the transfer optics section using high voltages from 5 more power supplies. Two of these power supplies in the transfer optics section require 0 to -2000 V with 16-bit accuracy. The accuracy of all power supplies in the ion source and ion optics is determined by the mass resolution requirements of the DFMS. Following the transfer optics section, ions pass through a wide range of ion optical elements, which ultimately focus a mass, dispersed ion beam onto several possible detectors including a high resolution, position sensitive detector. Since the ion source resides on spacecraft ground, the ion optics must float at high voltage acceleration potential. This floating acceleration potential is provided by a 14 bit full scale, 0 to -6500 V power supply. Also, since the optical elements float at this high potential, they are electrically isolated from the power supplies and instrument controllers that reside on ground. Communication to and from these isolated power supplies is provided by a serial interface across several fiber optics channels. The design for the fibre optics was derived from the successful design used in the Toroidal Imaging Mass Angle Spectrograph (TIMAS) [Shelley et al., 1995]. Power is supplied across a high voltage transformer.

In the original DFMS design, a mechanical slit was to be used to select high or low-resolution mass spectra. During DFMS prototype testing, this mechanical system was replaced with an electrical slit system powered by two 1000 V 12 bit power supplies directly behind the transfer optics. Following a corrective lens element accomplished by a set of plates at low voltage (0 to 50 V), the ions enter the electrostatic analyser. This analyser is powered by two 10 to 550 V 18 bit power supplies. The high accuracy is required because the ESA voltages are used to select specific ion energies and focus specific masses on the Channel electron multiplier in the detector section.

In the original design, critical elements in the DFMS electronics like the ESA power supplies were to be temperature controlled to very high accuracy. The resource requirements for this control proved to be prohibitive and a compromise control scheme was developed. The ESA voltage is temperature compensated using a pre-programmed lookup table in the ESA controller. The lookup table is pre-programmed during EAS voltage calibration to compensate the temperature changes in the voltage and keep the ESA voltage stable during the measurement cycle with stability approaching 4 parts per million (18 bit).

Following the ESA, the ion trajectory is again corrected in several optical low voltage optical elements (controlled by one 0 to ± 110 V and three 0- ± 50 V power supplies) prior to entering the permanent magnet. The magnet is a static element in the ion path but the temperature is monitored by the DFMS electronics.

Upon exiting the magnet, the ion trajectory is again corrected with a low voltage (0 to ± 110 V) prior to entering the zoom optics. When the optical elements in this section are not active, the DFMS is in low mass resolution mode and the mass dispersed ion beam impinges on the detector selected by the optical steering. When the four optical elements (powered by two 0 to ± 500 V 14 bit and two 0 to ± 2000 V 14 bit supplies) are active, the DFMS is in high mass resolution mode, and the ion beam that impinges on the chosen detector is considerably more dispersed in the transverse (mass) direction.

Through a high voltage transformer interface, the DFMS electronics also provides power to the CEM detector and repeller grid, the repeller grid for the faraday cup



detector and the front and back high voltages for the MCP. The MCP voltages are programmable to 10-bit accuracy to allow for safe HV detector turn-on and potential decrease in the MCP gain during the long encounter with the comet.

The entire electronics package is housed below the DFMS optics (see Figure 1.3.). Three packages are attached to the DFMS base plate. These packages consist of the Main Electronics Pack, the Acceleration Supply Pack, and the Floating Detector Pack. A fourth package discussed with the sensor is called the Remote Detector Pack.

The Main Electronics Pack consists of 8 electronics boards, a motherboard connecting these eight and a low voltage power supply board. These boards are all at the local spacecraft ground and are attached directly to the base plate for thermal dissipation directly through the feet of the base plate attached to the spacecraft.

- MEP-A data and command handler, interface with the DPU
- MEP-B ion source heater and calibration
- MEP-C mechanism control, controls cover and also contains the CEM detector high voltage
- MEP-D CEM processing electronics for the CEM data
- MEP-E Acceleration bias supply, providing the -6500 V floating potential for the ion optics
- MEP-F Filament bias supply, providing the ion source filament potential
- MEP-G Ion source controller, controlling the potentials in the ion source that accelerate and focus the ions
- MEP-H Transfer optics high voltage bias for the transfer optics
- MEP-K Transfer optics pre-regulator for the transfer optics high voltage power supplies
- MEP-M Motherboard which connects MEP-A through K (Residing below the baseplate)
- MEP-N Low voltage power supply which interfaces with the spacecraft power provided through the DPU

The Acceleration Supply Pack consists of 5 electronics boards. This pack floats at the VACCEL potential and the pack is electrically isolated from the base plate by high voltage standoffs. Thermal dissipation is accomplished through these standoffs as well as radiatively from the sides and ends of the pack.

- ASP-A Low-high voltage generating voltage for the FDP package, which floats at a potential above the ASP package
- ASP-B Digital Control for the ASP package, including the ESA ASP-C ESA high voltage, providing the 18 bit ESA voltages
- ASP-D Medium-high voltage, providing voltages for the optical elements after the ESA including the zoom optics.
- ASP-E Interface and power for the ASP pack, connected across a high voltage interface to the low voltage power supply in the MEP pack.

Detector electronics:

The required very large dynamical range led us to consider for the imaging detector an analog detection system wherein charges or currents are measured on a

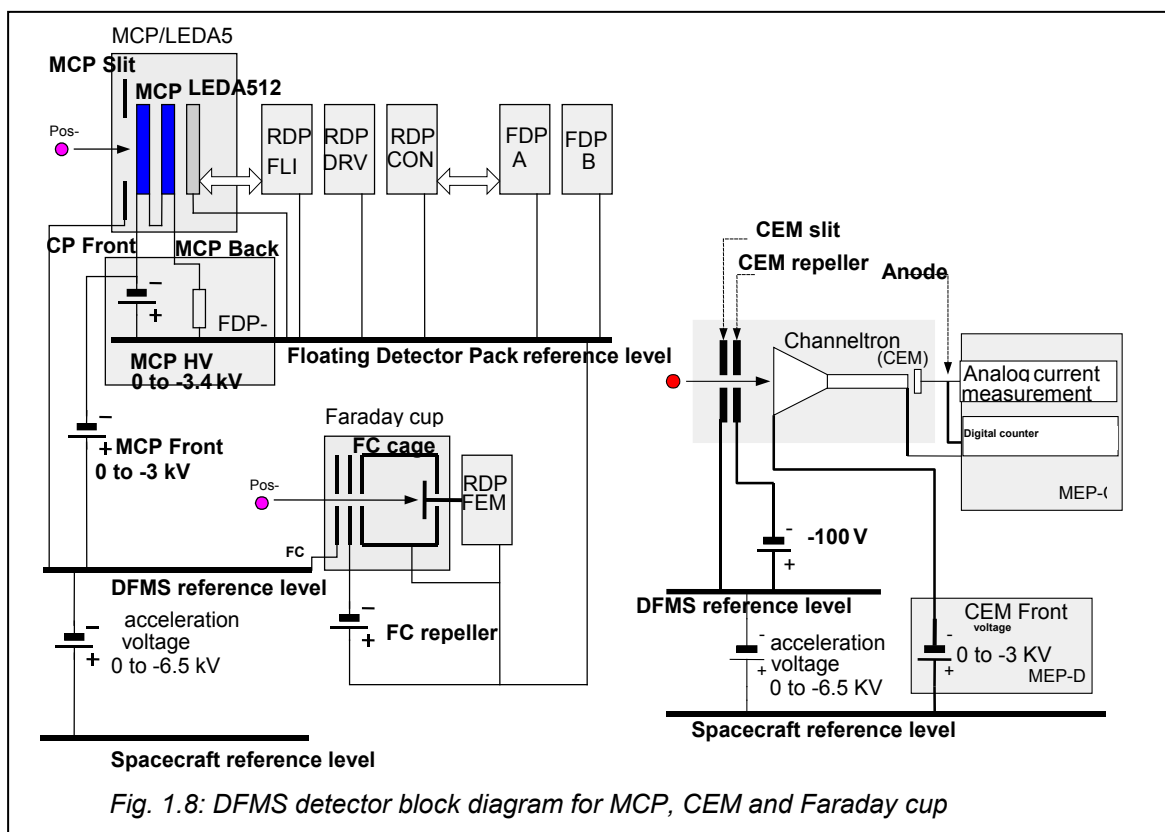

collector at the exit of the MCP. Indeed, in this analog mode, the gain of the MCP can be varied over more than 6 orders of magnitudes by proper adjustment of its supply voltage, as demonstrated, for example, on the NMS instrument of the GIOTTO mission. This fact, added to the dynamic range of the collector electronics itself, fulfils the specification indicated in section 4.1.2 above. In order to meet the resolution of $\sim 25\mu$ a new ASIC chip, the LEDA512 (Linear Electron Detector Array) was developed. This chip integrates two identical but independent detector systems, each one consisting of a collector under the form of a row of 512 anodes (or pixels)

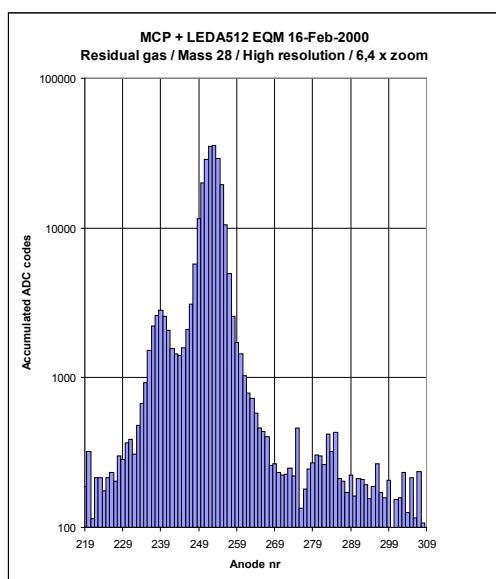
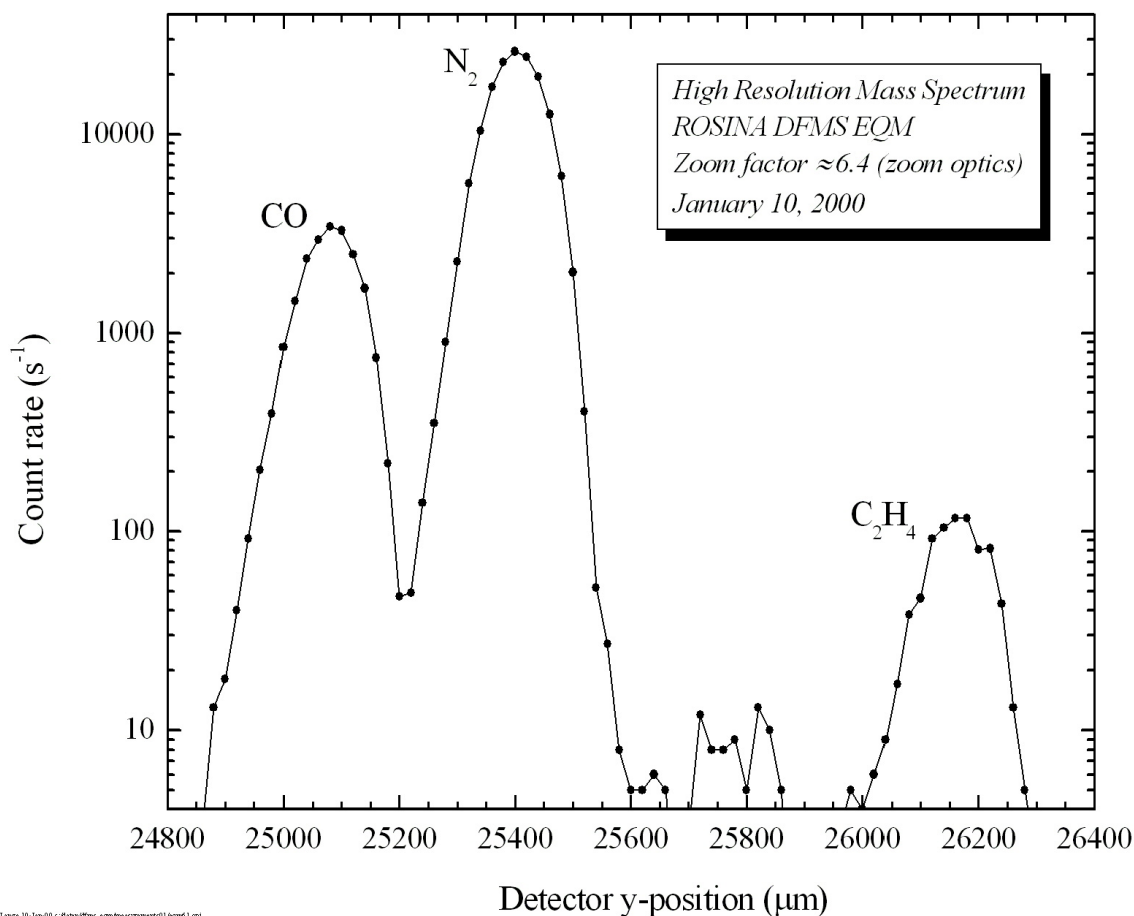

Fig. 1.9: LEDA response

collecting the electrons emitted from the back face of the MCP and of the associated charge integration electronics. With a pixel width of 22μ and a 3μ separation between adjacent pixels this collector has a length of 12.8 mm in the focal plane over a height of 8mm and each mass peak covers approximately 6 pixels. The back face of the MCP is at a distance of 0.2 mm from the plane of the collector. In the standard mode of operation electrons exiting from the MCP are proximity focused by an accelerating potential of ~ 250 Volts which allows to maintain their spreading within limits corresponding to the required resolution. Each individual pixel operates as the floating electrode of a condenser with the second electrode at ground; the capacitance of this capacitor is approx. 4 pF. During the read-out sequence which can be made as fast as 10ms



K. Lamy, 10-Jan-09, /Rosetta/ROSINA/DFMS/eqm/eqm01/eqm01.jpg

Fig. 1.10: High Resolution mass spectrum with the DFMS EQM

for the 512 pixels, each pixel is connected sequentially through an analog multiplexer to a charge amplifier. This amplifier provides at its output a pulse with an amplitude proportional to the amount of electron charges collected by the pixel and a 12-bit ADC then converts the pulse height into a 12 bit digital word stored in a spectrum accumulation memory. The instrument DPU through an opto-coupler link ultimately reads out this memory.

As a consequence of the accelerating voltage applied to the front face of the MCP and of the variable HV polarization between the front and the back faces of the MCP which controls its gain, the LEDA is at a “floating detector package” potential (FDP) which can reach several kV with respect to the DFMS reference level. In order to avoid leakage currents problems on the Faraday cup and difficulties associated with two different high voltages in the electronics installed in the detector package, the Faraday cup electronics is polarized at the same floating voltage as the LEDA. All together, the electronics of the detector package which is represented in figure 1.8, consists of 2 main parts:

- The Remote Detector Package (RDP) with 4 boards located just behind the collector and the Faraday cup. They include the most sensitive circuits, which need to be as close as possible to the LEDA and Faraday cup and the associated interface circuits with the FDP.



-The Floating Detector Package (FDP) with 3 boards mounted insulated on the DFMS base plate and which provide digital interfacing with the RDP boards, processing of the analog signals from the LEDA and FC and MCP floating HV and FDP power supply voltages. This pack floats at the detector acceleration potential (somewhat above VACCEL of the ASP). Like the ASP, it is electrically isolated from the base plate by high voltage standoffs and thermal dissipation is accomplished in

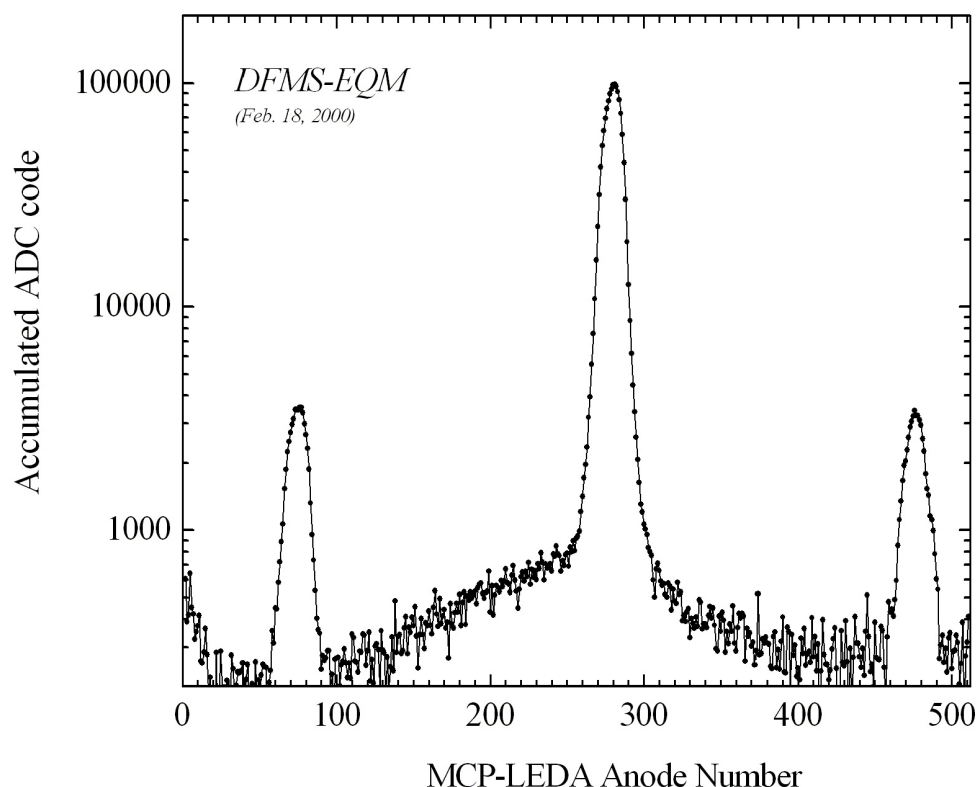

Fig. 1.11: Low resolution mass spectrum, $m = 27, 28, 29 \text{ amu}$

the same way as the ASP dissipation.

- FDP-A: Analog processing for the high resolution detector and the faraday cup detector
- FDP-B: Digital control for the detector
- FDP-C: Interface and power for the FDP package, connected across a high voltage interface to the low voltage power supply in the MEP pack.

Measurement sequences

The instrument has a large number of operational parameters, which could be individually adjusted to fit any specific measurement requirements. However, a certain number of predetermined modes and measurement sequences will be implemented and we expect that most measurements will be made using these. From time to time it will be necessary to retune all voltages to optimize the instrument performance and to compensate for mechanical, thermal, etc. drifts



which could occur during launch or in space. We expect that the basic retuning can be done autonomously, but some manual adjustments might still be necessary requiring extensive ground command sessions.

For any given instrument setting we will use a basic integration time of approximately 1 s. The accumulated spectra will be transferred to the DPU for further data processing. The adjustment of the instrument to a new setting, for instance a new value for the central mass requires about 0.5 s. This includes the time necessary to optimize the detector gain. A full high-resolution mass spectrum from 12 to 100 amu/q can thus be recorded in $79 \times 1.5 = 120$ s. A complete low-resolution spectrum from 12 to 100 amu/q can be acquired in $12 \times 1.5 = 18$ s. Telemetry limitations, even after data compression may not allow the transmission of all these data. Several 1 s spectra with the same settings will then be recorded either in sequence or cyclical and transferred each one to the DPU. After statistical analysis spectra recorded with identical settings will be added, compressed and transmitted as full mass spectra. This procedure optimizes the scientific data return from the instrument.

1.2.2 RTOF

The reflectron time-of-flight (RTOF) spectrometer was designed to complement the DFMS by extending the mass range and increasing the sensitivity of the full instrument package. TOF instruments have the inherent advantage that the entire mass spectra are recorded at once, without the need of scanning the masses through slits. With a storage ion source - a source that stores the continuously produced ions until their extraction into the TOF section - with high transmission in the TOF section and with a sensitive detector, it is possible to record a very large fraction (>60%) of all ions produced in the ion source. These factors contribute to the overwhelming sensitivity of TOF instruments. Another reason to use TOF instruments in space science is their simple mechanical design (their performance depends on fast electronics rather than on mechanical tolerances) and easy operation. An RTOF-type instrument was successfully flown on the GIOTTO mission to measure atoms and molecules ejected from a surface during impact of fast cometary dust particles.

Fig. 1.12. shows the principle of the realized RTOF sensor. A time-of-flight spectrometer operates by simultaneous extraction of all ions from the ionisation region into a drift space such that ions are time-focused at the first time focus plane (TF) at the beginning of the drift section. The temporal spread of such an ion packet is compressed from about 800 ns at the exit of the ionisation region to about 3 ns

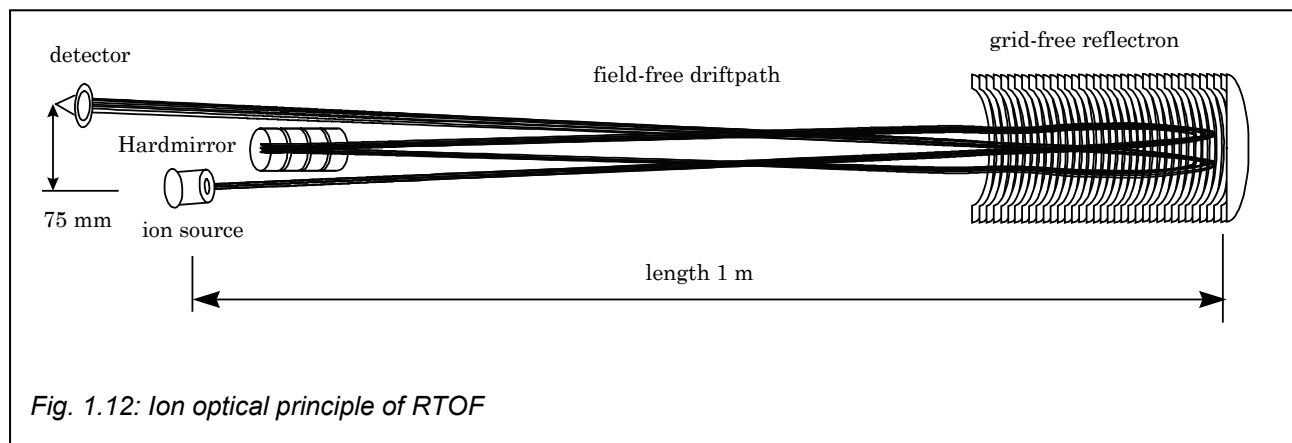

Fig. 1.12: Ion optical principle of RTOF



(for mass = 28 amu/e) at the first time focus plane. These very short ion bunches are then imaged onto the detector by the isochronous drift section. Because different m/q bunches drift with different velocities, the length of the drift section determines the temporal separation of the bunches. If properly matched to the drift section, the reflectron establishes the isochrony of the ion-optical system. The mass resolution is determined by the total drift time and the temporal spread of the ion packets at the location of the detector. Unlike other types of spectrometers, TOF spectrometers have no limit to the mass range. In practice the mass range is limited by the size of the signal accumulation memory.

The ROSINA RTOF sensor includes two almost independent mass spectrometers in one common structure. The spectrometers share the principal ion-optical components, the reflectron and the hard mirror. The ion sources, the detectors and the data acquisition systems are separate. The electron impact storage ion source is dedicated to analysing neutral particles, and the orthogonal extraction ion source is assigned to analyse cometary ions. This configuration guarantees high reliability by almost complete redundancy.

1.2.2.1 Ion Optics

The RTOF sensor consists of five main components: the ion sources, the ion optics, the reflector, the hard mirror and the detectors. Two different channels are used in this spectrometer: one in which cometary gas is ionized and stored in an ion source, and one that pulses the incoming cometary ions directly onto the TOF path. The two ion sources are mechanically very similar, with one source optimized for gas measurements and one source optimized for ion measurements.

Electron impact storage ion source

To achieve high sensitivity it is necessary to produce ions continuously, to store the formed ions for a certain time and to extract them at regular intervals into the TOF analyzer. This is done by the electron impact storage ion source, which is shown in the schematic illustration of Figure 1.13. The ion source has a rotational symmetry with the exception of the filament-repeller assemblies. The section plane shown in fig. 1.13 is representative for the three-dimensional model.

Fig. 1.14: Schematic of the RTOF orthogonal extraction source

Fig. 1.13: Schematic of the RTOF electron impact storage source

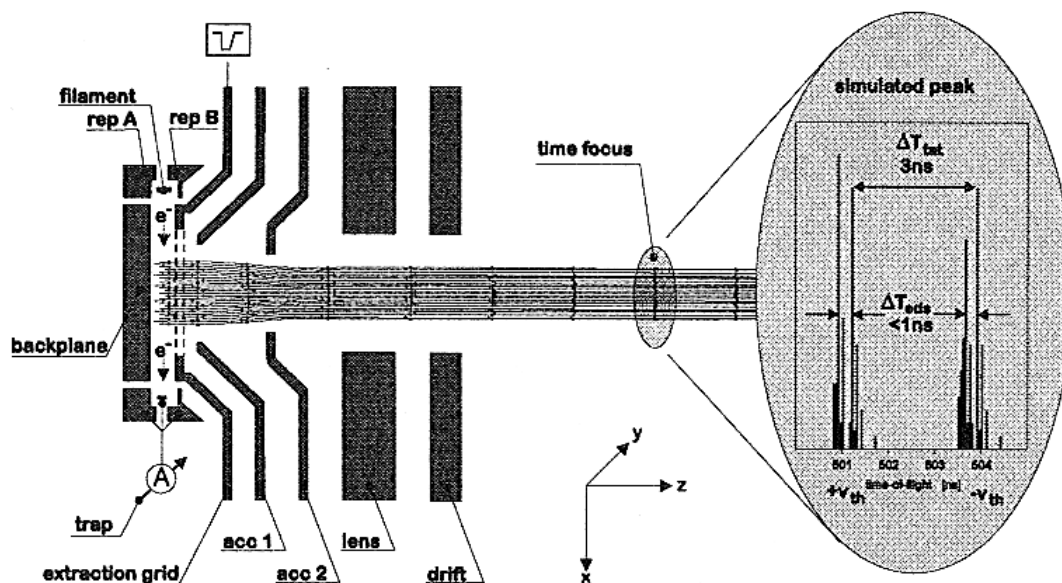

The ion source contains a double filament assembly for redundancy reasons. Only one filament is active at a time, and it emits electrons, which are accelerated to energies of up to 70eV. The electron beam can be guided through the extraction



zone using the two repeller electrodes (rep A and rep B). The inactive filament-repeller assembly located on the opposite side of the extraction zone is used as an electron trap to monitor the electron emission. A constant number of passing electrons ensure a constant ion production. The continuous electron beam ionises gas atoms in the region between the back plane and the extraction grid. The ions are kept in the potential depression generated by the space charge of the electron beam. For a nominal repetition rate of 10 kHz the continuously created ions have to be stored for 100 μs ; the applied extraction pulse lasts for 1 μs . The applied extraction voltage is about 350 V. This corresponds to an electrical field strength of $E_s = 175 \text{ V/mm}$ in the ionisation region (the distance between the back plane and the extraction grid) of 2 mm length as shown in Figure 1.13. The final energy of the extracted ions is obtained after passing two acceleration electrodes. An additional electrostatic lens located after the acceleration electrodes is used to form a parallel ion beam of diameter $\approx 5 \text{ mm}$ at the source exit. For the nominal total ion energy of 3.5 keV this extraction voltage results in a maximal energy dispersion of 10% for the ions. 1/2011: This energy had to be lowered due to HV discharges in the high voltage converter and is currently 1 keV. However, the time-of-flight dispersion for an energy dispersion of that magnitude is kept minimal by the use of a second-order time focusing TOF system. The mass resolution of the RTOF sensor is mainly determined by temporal spread of the ion bunches at the first time focus, thus given by the performance of the ion sources. The extracted ions are compressed to ion packets of several nanoseconds duration at the time focus plane located approximately 5 cm after the ion source. By a suitable choice of the acceleration potentials second-order focusing at the first time focus plane is achieved. The temporal spread of the ion packet at the first time focus plane is then mostly governed by the turn-around time in the extraction region. The turn-around time is the time necessary to reverse the direction of an ion with its initial velocity (typical 0.1 eV) directed against the extraction direction of the ions by the extraction field in the source.

Orthogonal extraction ion source

The concept of the orthogonal extraction ion source was initially introduced for cluster ion measurements to provide an improvement to the limited resolution of conventional TOF instruments of the Wiley-McLaren type [1955]. The orthogonal extraction ion source allows for easy coupling of a TOF-MS with a wide range of external continuous or pulsed ion sources. In the case of the RTOF sensor the orthogonal extraction ion source is dedicated to the measurement of the ionised component of the cometary atmosphere. The orthogonal extraction ion source uses off-axis created ions, ions either coming from an external ion source—the comet in our case—or using ions formed by electron impact ionisation in an off-axis electron impact ionisation assembly. The orthogonal extraction ion source is shown in the schematic illustration of Figure 1.15. These ions propagate orthogonally to the principal ion-optical axis of the TOF system with an initial energy of about 10 eV. When passing through the extraction region of the orthogonal extraction ion source part of these ions are extracted by a fast voltage pulse on the extraction grid and are further accelerated onto the drift path of the TOF system. The small duty cycle resulting from pulsing ions out of a continuous beam is one of the major drawbacks



Fig. 1.16: Integrated reflectron

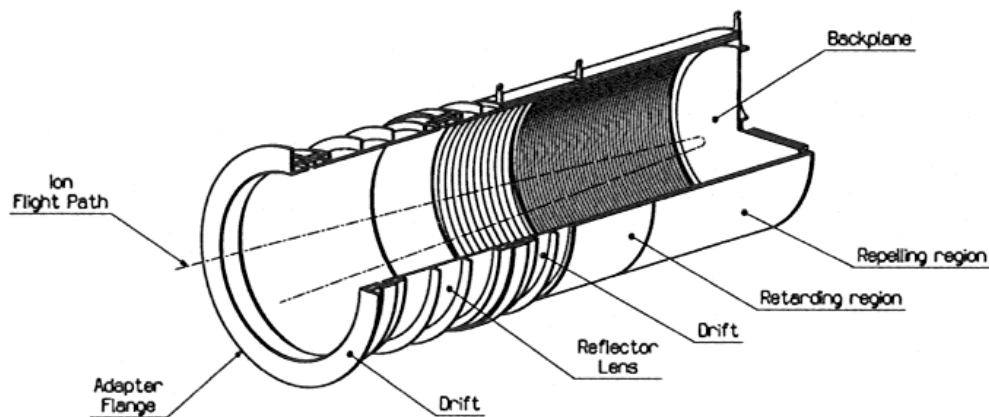

of the orthogonal extraction ion source. The final energy of the extracted ions on the drift sections is again 3.5 keV. The energy is achieved using a two-stage acceleration region allowing for second-order focusing at the first time focus plane. The ion source consists of a rotational symmetric ion extraction and acceleration section and the off-axis ionisation assembly mounted perpendicularly to the former (see Figure 1.12). The extraction and acceleration section of the orthogonal extraction ion source are the same as in the storage ion source. The filament and trap assemblies are planar symmetric in the plane of the drawing. Cometary ions are pulled into the entrance system of the off-axis ionisation assembly by an external attraction grid and their energy is adjusted to be about 10 eV by suitable acceleration or deceleration. The entrance section also has a filament assembly to create ions from in-flowing gas by electron impact ionisation. The ions are accelerated to form a continuous ion beam orthogonal to the principal ion optical axis of the TOF system. The following skimmer arrangement minimizes the velocity components in and against the direction of the principal ion-optical axis of the TOF system. Therefore, the turn-around time, which is the limiting factor for the mass resolution of the system, is largely reduced resulting in a higher mass resolution of the ion channel than the gas channel.

Reflectron: The reflectron represents a key ion optical element of the RTOF sensor, necessary to achieve the desired scientific performance. Basically, the reflectron is an ion-optical mirror at the end of a field-free drift path to redirect an incoming ion beam by an appropriate choice of repelling electrostatic fields. Thus, the field-free drift path is used twice and therefore the flight path is doubled maintaining the overall geometrical dimensions of the sensor. The technical design requirements made it necessary to come up with a completely novel reflectron design, shown in a schematic representation in Fig. 1.16.

Due to the initial energy distribution of the ions and the resulting negative time-of-flight dispersion, the temporal width of an ion packet will increase after the first time focus with increasing distance when moving along the field-free drift path. In the ion



mirror, ions with a higher energy penetrate deeper into the repelling field before returning than do lower energetic ions. Consequently, the faster ions have a longer time of flight through the reflectron than slower ones. By careful selection of the electric fields this effect allows to compensate over a wide energy range the negative time-of-flight dispersion on the field-free drift path. This time-focusing property of the ion-mirror for a given drift path length is often referred to as isochronous operation, since the flight time does not depend on the energy of the ions. The energy range of isochronous operation is $\pm 10\%$ of the nominal energy for this design. Therefore, ions with a specific energy distribution and the same m/q -ratio will reach the detector plane simultaneously. The reflectron generates an image of the first time focus after the ion source to a time focus at the exit path with reversed velocity vectors for the ions.

The step from a discrete two-stage reflectron to a grid-free reflectron is made by simply omitting the grids. The omission of grids makes the mechanical design of the reflectron easier and avoids transmission losses due to the limited ion-optical transparency of the grid, which is significantly lower than the geometrical transparency. However, the homogeneous electrical field configuration with parallel equipotential lines changes into curved equipotential lines by superposition of the different potentials applied to form the retarding and repelling electrical field. The curved potential contour lines geometrically influence the passing ion trajectories. Therefore, a grid-free reflectron also has geometrical focusing or defocusing properties. Due to the positive voltages in the reflectron with respect to the drift path, the entrance part acts like the first half of a positive electrostatic lens. A grid-free reflectron always shows lens effects for ions travelling out of the line of the ion optical axis. An ion beam will diverge in the entrance of a reflectron as it does in the entrance of a positive Einzel lens. To reduce the positive lens effect of the reflectron itself, a negative lens, the reflectron lens, is used at the reflectron entrance. The reflectron lens offers the opportunity to optimise the time focussing with the reflector potentials and independently to optimise the geometrical focusing with the potential on the reflector lens. The adjustment of the reflector lens voltage allows also manipulation of the inclination angle of the returning ion trajectories with regard to the ion optical axis of the system. Therefore, generally a grid-free reflectron with an integrated electrostatic lens at the entrance no longer shows the characteristic of a homogeneous ion mirror that the angle of incidence is equal to the angle of emergence. The practical application of this feature is demonstrated for the different operation modes of the RTOF sensor.

The electric fields for a reflectron are usually established by a set of rings connected to a resistive voltage divider. We designed a novel approach for generating the retarding and repelling electrical fields where the voltage divider is an integral part of the reflectron, which we called integrated reflectron or helix reflectron. The voltages and thus the electrical fields are defined by a voltage drop over a resistor in the form of a helix applied to the inner surface of a ceramic tube with an inner diameter of 78 mm (see Fig. 1.13a). The potential drop is constant along the helix and complements exactly the helix pitch. Therefore, the integrated reflectron shows no electrical fringe field zone in close proximity to the cylindrical boundary given by the mechanical structure. An ideal electrical field for the grid-free reflectron is generated in the entire inner volume of the structure. The total resistance over the helix is

designed to be about $10^9 \Omega$. The resistance has to be high to keep the power consumption of the HV supply low but also it has to be low enough that absorbed charges won't change the potential distribution in a noticeable way. The minimum resistance is determined from the maximum ion current of about 1 nA extracted from the ion source and the required adjustment accuracy for the reflector voltages of about 1 V.

The resistor helix is painted in a specially developed procedure at the inner surface of a ceramic tube, and afterward is subjected to a sintering process. Manufacturing and processing of the integrated reflectron was performed at GVE/EMPA in Zürich, Switzerland. The helix consists of two segments, where the length of the retarding segment is half the length of the repelling segment, but the voltage drop over the retarding segment is two times the value for the repelling segment, according to the second-order focus conditions. The voltage drop over the reflectron is controlled at

Fig. 1.17: Hard mirror

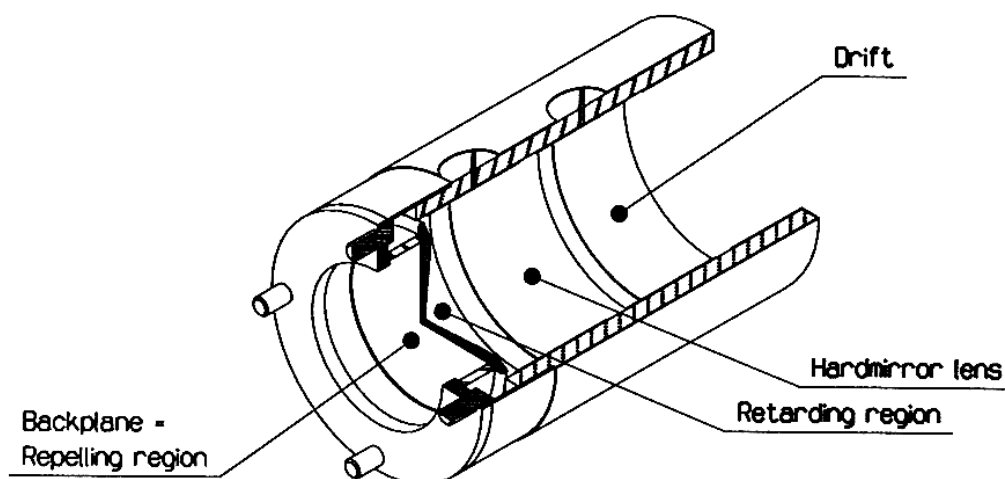

three points.

Furthermore, the ceramic structure of the integrated reflectron acts simultaneously as the ultra-high vacuum enclosure for the RTOF sensor and is an integral part of the overall mechanical sensor structure. The ratio of the ion optically usable inner diameter (78 mm) and the mechanical outer diameter (80 mm) is minimized. This results in a 50% weight saving compared to the classical ring stack reflectron, which requires an additional vacuum housing and high voltage feed-throughs. A photograph of the realized integrated reflectron is reproduced in Fig. 1.13b.

Hard mirror

The hard mirror represents an additional reflecting element in the RTOF system [Hohl et al., 1999] and is shown schematically in Fig. 1.14. The hard mirror increases the flight path in the RTOF system by almost a factor of two by introducing an additional reflection, while maintaining the initial time spread generated in the ion source. This also increases the mass resolution by almost a factor of two.

The hard mirror consists of cylindrical tubes with a sophisticated formed back plane.



Restricted by the narrow space between ion source and detector (see fig. 1.10), the hard mirror has to fit geometrically in the TOF system without substantially increasing the distance between ion source and detector to keep the angle between the incoming ion trajectory and the outgoing trajectory in the reflectron as small as possible. The reflecting region is short compared to the grid-free reflectron and thus performs a “hard” reflection, which means the penetration depths of ions of different energies are almost the same. The time focus of the hard mirror is chosen to be close to its exit plane since the hard mirror has limited time focusing capabilities due to its small size. Similar to the previously described grid-free reflectron, the hard mirror contains a negative electrostatic lens at the entrance to shape the ion trajectories spatially. Subsequently, the cylindrical electrodes following the hard mirror lens, in conjunction with the back plane, allow the adjustment of the retarding and repelling electrical fields.

The hard mirror offers the unique opportunity to suppress selected mass lines by applying a pulsed defocusing voltage to the back plane electrode (see Fig. 1.14). The electrical field configuration during the applied “blank-pulse” results in a strong geometrical defocusing of ions travelling not along the rotational axis. Thus, these ions will be lost by scattering inside the drift tube structure and will not reach the detector. Due to the short image length of the hard mirror, the longitudinal separation of iso-mass ion packets in the hard mirror itself is small compared to the hard mirror length, and allows for moderate blank-pulse amplitudes to exclude individual mass lines. The pulse slope requirements are less stringent compared to the extraction pulse.

The hard mirror structure for the flight model is based on a ceramic tube body with an inner diameter of 36 mm. Three conductive silver ring electrodes are applied on the inner surface of the ceramic body with a sophisticated shaped back plane defining the repelling potential surface. The passing ion trajectories in the immediate vicinity of the hard mirror demand an appropriate shielding of the electrical fields inside the hard mirror towards the field-free drift section by minimizing the field penetration. For this reason the hard mirror contains a conductive coating on the outer surface connected to drift potential and an extended entrance ring electrode with the same potential as the drift section.

Detector

Detecting single-ion events as well as ion bunches with up to 10^5 ions arriving within nano seconds time requires a detector with high detection efficiency. Furthermore, the detector has to have the ability to linearly amplify the incoming particles over a wide dynamic range. In order to minimize the time spread of the ion bunches registered on the detector, sufficiently fast detectors with an internal time response for single-ion events of less than one nano second have to be used. A narrow time width not only improves the mass resolution but also increases the peak amplitude and therefore improves the signal-to-noise ratio. The geometry in the ROSINA RTOF limits the diameter of the ion beam to 12 mm. For mass saving reasons the active area of the detector is therefore only 18 mm. Micro-channel plates of imaging quality have been selected for registering the ions; micro-sphere plates turned out to be not stable enough over the projected lifetime of the RTOF sensor. The critical issue for the detector is the anode design, which has to ensure a 50Ω impedance coupling of the electron pulse released from the channel plate into a standard



transmission line with minimal signal reflections and distortions [Wurz et al., 1994, Wurz et al., 1996]. The detector output is capacitively decoupled from the anode and thus allows the detector unit to float electrically. The transition line yields directly into a SMA output connector to connect the signal line. The signal is routed through semi-rigid cable (impedance $Z_L = 50 \Omega$) and extra-high-frequency tri-axial vacuum feed-through (rated 4 GHz) to the data acquisition system to minimize the noise pickup. The measured pulse-width for a single-ion event of this detector including the signal routing is about 500 ps. The detector contains an integrated voltage divider to provide the various voltages needed to supply the two MCP stages in the detector. The voltage divider is built on a ceramic substrate with ultra-high vacuum components to ensure short electrical connections for fast replenishing of the extracted charge of the MCPs [Wurz et al., 1996]. The detector can be operated in analog mode or in pulse counting mode.

1.2.2.2 RTOF scientific operation modes

The RTOF flight instrument will provide several scientific operation modes to assure optimal scientific data acquisition under diverse mission conditions. The gas and ion modes, with their dedicated ion sources, have their own optimized data acquisition system. The RTOF sensor on the Rosetta spacecraft will have the following operational modes, all of which were tested with the RTOF laboratory prototype.

Single- and triple-reflection mode

The single-reflection mode refers to the ion trajectories starting at the ion source, being one time reflected in the reflectron and ending at the detector (see left drawing in Figure 1.10). In the triple-reflection mode, the ions leave the ion source, reverse their direction of motion for the first time in the reflectron, and experience a second reflection in the hard mirror. After a third reversal of their direction of motion in the reflectron, they will hit the detector. The reflectron is used twice in this mode and the hard mirror is passed only once. Switching between the single- and triple-reflection mode is done with the reflector lens by a change of the lens voltage. The single-reflection mode requires a typical reflectron lens voltage of about -2200 V below the drift potential, whereas the triple-reflection mode operates with a reflector lens voltage of -4650 V below the drift potential. There is no mechanical tilt element to be operated in flight nor are there electrical deflection plates, which could redirect the ion beam between the single and triple reflection mode. The gas and ion channel must always operate in the same mode because of the commonly used reflectron structure and the differing voltage set for the single- and triple-reflection mode.

Gas mode

The gas mode is assigned to the electron impact storage ion source and analyzes initially neutral particles. During the storage period up to 10^5 ions will be accumulated in the ion source and released by an extraction pulse firing into the TOF analyzer section. The data acquisition system has to be able to record the detector signal proportional to the number of incoming ions. The data acquisition system has to be able to record the detector signal proportional to the number of incoming ions. In flight, the gas mode signal is processed with the Equivalent Time Sampling (ETS), which is described below.

Ion mode

The ion mode is performed with the orthogonal extraction ion source dedicated to

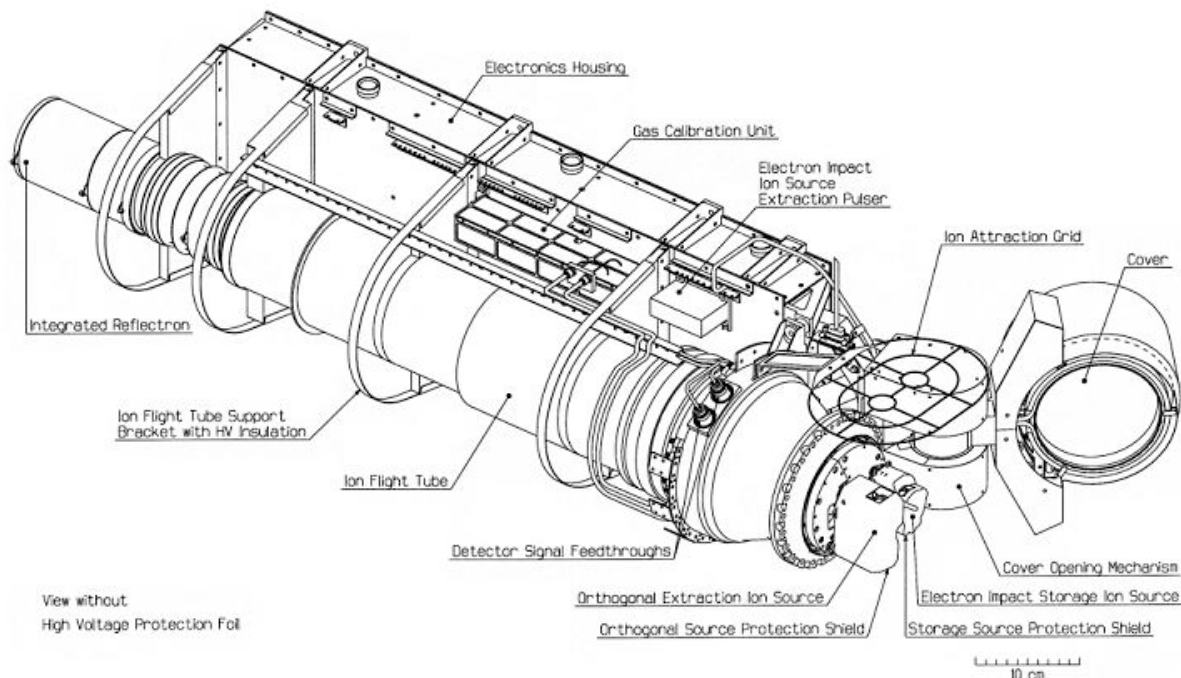

sensor will be launched under vacuum conditions and the cover only opened in space to minimize contamination.

RTOF has an identical in-flight calibration system as the DFMS sensor (see above), except that in this case each ion sources has its own gas line.

The secondary structure is made from aluminum and houses eight electronics board and the three pulsers (two for the ion sources, one for the hard mirror).

1.2.2.4 Electronics

The entire electronics of the RTOF instrument consists of the following 10 functional blocks:

1. Main Controller (MC):

The MC handles the commands coming from the DPU and the Data and Housekeeping going to the DPU. It contains the following blocks:

- Motor Driver for the cover
- Housekeeping unit
- Power switching unit
- Filament emission
- Gas calibration unit
- Hard mirror pulser
- ETS latch up disable

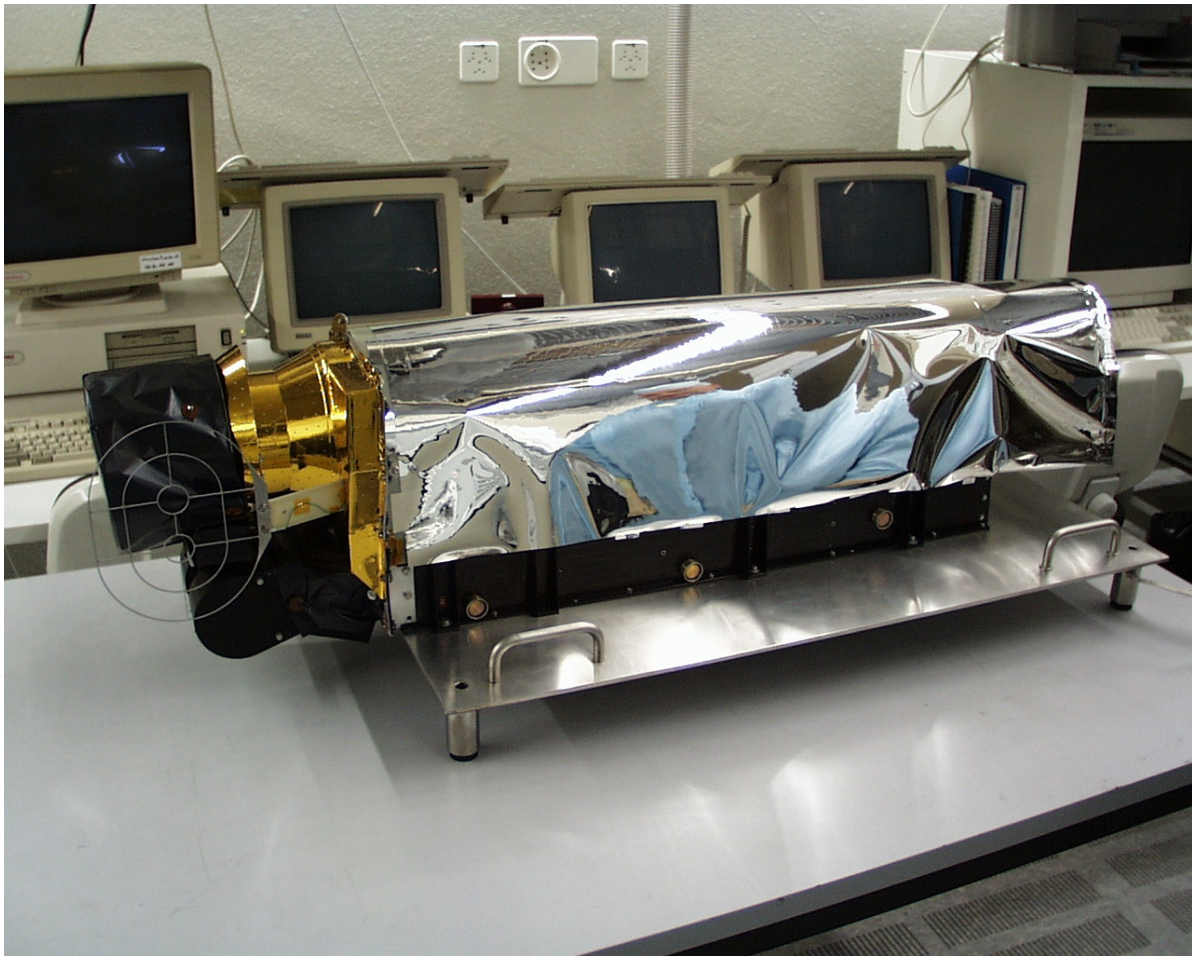

Fig. 1.20: RTOF electrical qualification model

- Differential serial interface to the DPU
 - Gateway switches for ETS,ETS-Light, Digital Board
2. *Equivalent Time Sampler (ETS)*
 - Data acquisition system for fast and non-repetitive signal pulses.
 3. *Equivalent Time Sampler, Light (ETS-L)*
 - Data acquisition system for fast, non-repetitive single ion pulses
 4. *High Voltage Board #1 (HV#1)*
 - Supply for Extraction, Hard Mirror, Acceleration, Lens, Reflector and drift voltages.
 5. *High Voltage Board #2 (HV#2)*
 - Supply for extraction grid, detectors and hard mirror pulser voltages.
 6. *Low Voltage Power Supply (LVPS)*
 - Supply for analog $\pm 5V$, dig. +5V, +8V, analog $\pm 15V$, +24V, +35V, +55V.



7. Digital Board for power supplies

- Back plane, entrance lens and entrance supplies, controller for the supplies, HK and MC.

8. Gas Calibration Unit (GCU)

- Contains two full redundant units for the in-flight calibration with a gas of defined composition.

9. Ion, Gas and Hard Mirror Pulser

- The Ion and Gas pulsers perform the extraction with a negative pulse with a fast falling edge and a medium fast rising edge. The amplitude is programmable.
- The Hard Mirror Pulser deflects charged particles before they hit the detector with a positive pulse from a positive Hard Mirror potential. Pulse width, delay from trigger and pulse amplitude are programmable.

10. Filament Emission Controller (FEC)

- The FEC regulates the emission current of the Gas and the Ion Source filament. It also contains the selection of the redundant filament sets in case of failure.

Equivalent Time Sampling System (ETS)

The ETS is one of two data acquisition systems in the RTOF sensor to digitize analog signals. It is a multiple ADC high speed data acquisition unit that is especially designed for fast and non-periodic pulses recorded by the Micro Channel Plate (MCP) detectors. 16 high speed, 8bit low power ADC's are fired with a 2ns delay, *Fig. 1.120: RTOF electrical* after an input signal exceeds a 3 bit programmable trigger level (10-100mV). The delay between the occurring waveform and the ADC start is less than 3 ns to minimize the trigger jitter. The sample and hold gate time is 1 ns. The signal source can be selected by DPU command out of the 2 inputs, one for the ion and one for the neutral channel. The signal bandwidth is about 800MHz to record with minimal signal distortion. Both inputs are terminated to 50Ω and are AC coupled. The inputs are protected to ±1.5 V.

The system must be enabled by the DPU command to start acquisition. The data acquisition sequence then is started with the internal generated start signal going to the ion or to the neutral extraction pulser. There is the option to run the unit in a half synchronized way with an external trigger. Instead of starting the system periodically by the internally generated extraction clock, the circuitry waits for the external trigger from ETS_L to get started. A jitter of approx. 32ns relative to the external trigger might occur to get the ETS internal state machine synchronized. For testing and stimulating the electronics, a stimulator is available that generates an analog signal 1 ns ...255 ns width. Amplitude and width are programmable with 8bit. The stimulated signal TOF after an extraction is programmable with 13-bit (32 ns resolution).

An 8-bit conversion takes 2.5 clock cycles at 50 MHz. The ADC units are designed for asynchronous operation to save power. Each unit contains an S&H circuit and



the ADC as well as the control logic. The dead time between two trigger events, generated from an incoming waveform, is 7 Clock cycles (224 ns). For the case that a time gap free sampling is required, the system can be set into the "Time Delayed Sampling Mode", where the acquisition start delay value is not fixed, but increased automatically by 32ns after each extraction.

Four 512x18bitx2 FiFo's are used for fast data storage. 4 sets of ADC data are stored in each FiFo. The Time of Flight (TOF) measurement is the base for the address generation at which the data are stored in the accumulation RAM. The address is stored in a 512X18bit FiFo. The Start Delay Time and the Time Of Flight can be programmed with 17-bit each, that refers to 131.073 μ s. That means a total time of 262,144 μ s can be covered. After the programmed times are elapsed, the accumulation of the data is initiated. 8 bit data are accumulated to a 24 bit wide word as well as the number of events for each channel. So altogether 48 bits belong to a single time of flight address. These data are transferred to the DPU after a valid readout command has been received. Data acquisition has the highest priority.

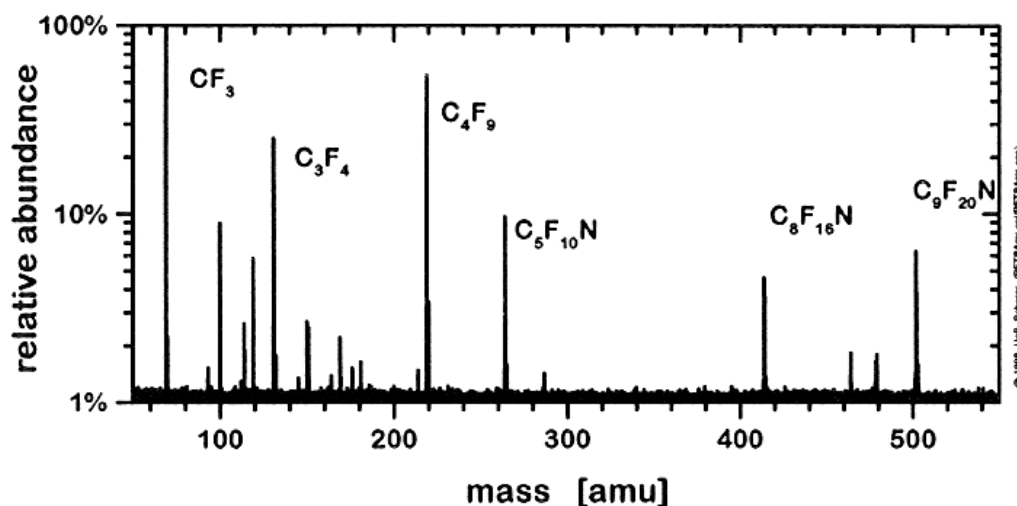

Fig. 1.21: Mass spectrum of the calibration compound heptacosafuorotributylamine

Readout will be performed after the data accumulation is finished and settings become valid after the accumulation is finished.

For high event frequency the extraction will be kept disabled as long as the accumulation is not yet finished completely. That could mean that the extraction rate is smaller than programmed. For this reason there are two 24 bit counters implemented to count the initial extraction rate and the actual rate. Another counter is for the external trigger source. These data are transferred to the DPU between the header block and the accumulated data.

Equivalent Time Sampler - Light

This board has the same feature as the ETS except that there are no ADC's. It

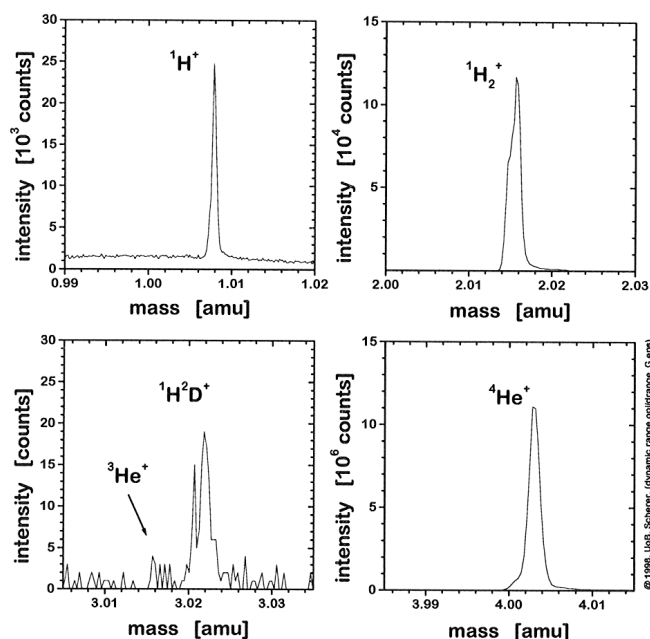

Fig. 1.22: Mass spectrum for a mixture of helium and hydrogen

therefore works as a time to digital converter (TDC) system. As long as there are no multiple simultaneous ion impacts on the detector this is sufficient. For the orthogonal source where the intensity is much less than for the storage source this is sufficient.

Gas Calibration Unit (GCU)

The GCU (Gas Calibration Unit) is designed as a sub component of the RTOF Instrument. It will be used as a stimulating device by the injection of a gas mixture (noble gases) into the Gas-

Source and Ion-Source if selected. By source stimulating with noble gases (with well known masses), TOF parameter can be calibrated with regard to mass resolution.

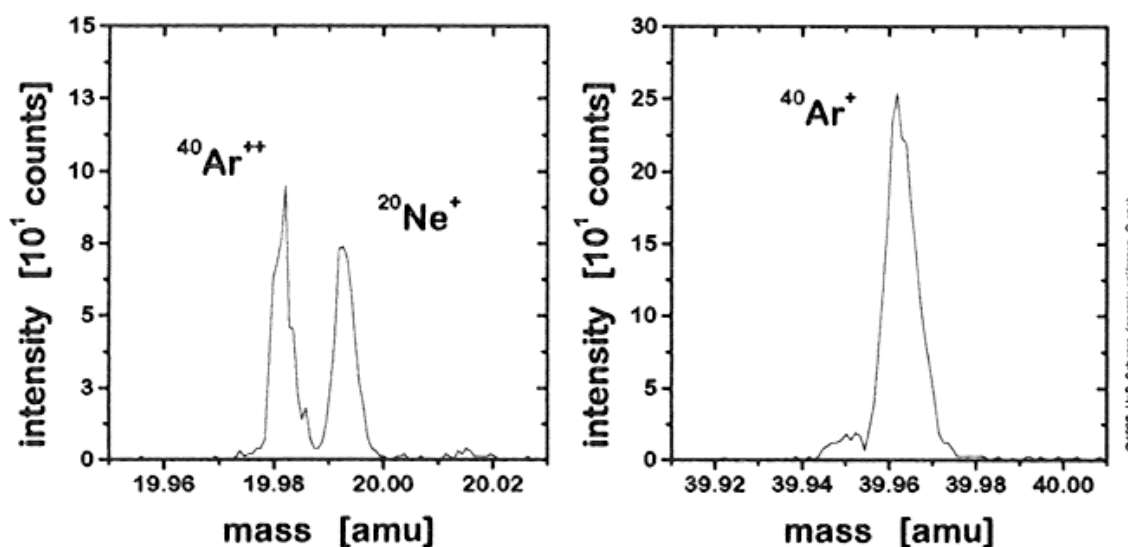

Fig. 1.23: Argon mass peak in a noble gas mixture

For the two source stimulation purpose two similar gas pipe structures are designed, which are individual remote controllable. Both gas pipes are hosted in a common housing and carried on one electronic board. The two pipes consist out of tank, high

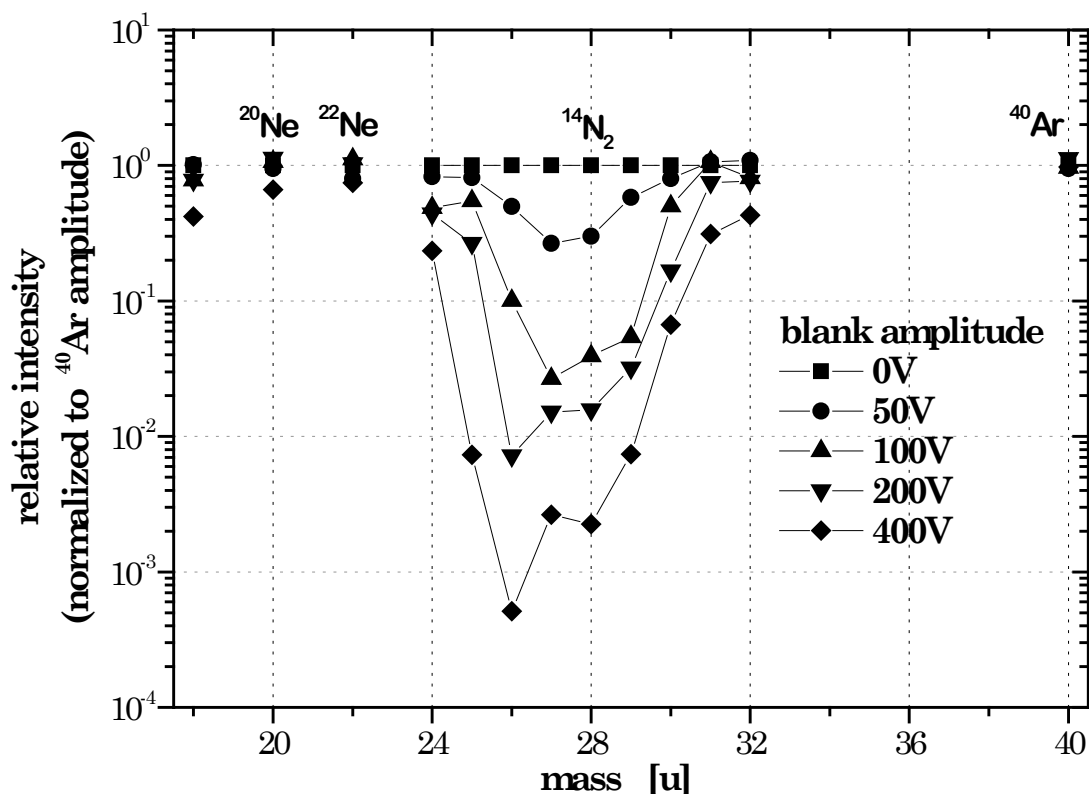

Fig. 1.24: Signal strength for masses 18 to 40 amu/e for a noble gas mixture normalized to the signal without blank pulse at the hard mirror.

pressure gauge, valve, low pressure gauge (mini pirani) and a capillary tube with a standard CAJON vacuum connection at the very end of the unit. All sub components have to be fabricated very clean to avoid any gas contamination. Leakage rate for all components and mounted pipe with close valve is defined as $\leq 10^{-10}$ mbar l / s .The controllable pressure range of the low pressure gauge can be defined between 10^{-3} mbar l / s and 10^{-1} mbar l / s. The necessary gas beam depends very strong of the injection position of the very end of the additional gas tube (which connects the GCU outputs with the sources) and the preferred parts intensity to be analyzed.

Preliminary tests have shown sufficient control range of the mini pirani circuitry to allow source stimulation. The GCU can be separately powered by +/-5V DC and +6V (for valve resistor) in both gas pipes. The output pressure of the individual gas pipes can be controlled in a closed loop circuitry. A set value has to be used as control value (earned by pre calibration) and a converted pressure value is detected via housekeeping by the DPU. The DPU software should be able to make comparison between Set value and measured value, which leads to, the ON/OFF command for valve heating. The command is send to the Main Controller (MC), which is able to switch the selected valve resistor ON or OFF. About 4 actions per s for the DPU should be enough to get stable gas flow into the Sources.



1.2.3 COPS

The COPS (Comet Pressure Sensor) consists of two sensors based on the Bayard-Alpert ionisation gauge principle. The first gauge, called the « nude gauge » will measure the total pressure (more exactly the density) of the cometary gas. The second gauge, called the « ram gauge », will measure the ram pressure (equivalent to the cometary gas flux). From the two measurements, the expansion velocity can be derived.

1.2.3.1 The nude gauge

Free electrons emitted from a 17 mm filament at +30 V are accelerated towards a cylindrical anode grid (20 mm diameter 40 mm height) at 150 V. Inside the anode the thin molybdenum wire (0.15 mm diameter 38 mm long) collector is mounted and connected to an electrometer. The electrons follow an orbital motion around the collector ionising the gas along their path. The measured ion current is directly proportional to the density. The density is measured by an extractor-type gauge (Redhead 1966), which measures lower pressures (no X-ray limit) than a typical Bayard-Alpert gauge and shows better reproducibility. Indeed the ion collector is hidden by a shield from the X-rays generated by electrons hitting the anode grid. The created ions are collected thanks to a 3-element electrostatic lens-like system (anode-shield-Reflector). The anode (20 mm diameter 32 mm height) is at 180 V. Such configuration prevents also solar UV to reach the collector. The gauge is decoupled from the surrounding plasma by an external grid maintained at -12 V (spacecraft potential).

Two filaments will be available for redundancy addressable by a switch. Presently made of 3 ReW (as flown on Giotto (Krankowsky et al. 1981)) investigations are continuing to improve the filament lifetime in the water-rich cometary environment. Each filament can emit up to 1 mA regulated on the current trapped by the anode. Taking into account the range of the electrometer and the X-ray limitation the expected pressure range is 10^{-9} - 10^{-4} mbar. The preliminary results from the laboratory prototype indicate a sensitivity of $\sim 3 \text{ mbar}^{-1}$ for nitrogen.

1.2.3.2 The ram gauge

A spherical cavity 60 mm diameter with a 6 mm aperture facing the comet stands on a hollow boom. A screen prevents the gas from directly impinging in the boom where the density is measured (Fig. 25). The configuration allows the gas to be isotropised and thermalised to the wall temperature before it reaches the ionisation area. The conductance of the top aperture is 3.4 l s^{-1} for the water at 200K giving an equilibrium time (Bermann 1985) of less than 200 ms for the system. The real response time of the instrument is driven by the electrometer (see below). The



density is measured by an extractor-type gauge (Redhead 1966), which measures lower pressures (no X-ray limit) than a typical Bayard-Alpert gauge and shows better reproducibility. Indeed the collector is hidden by a shield from the X-rays generated by electrons hitting the anode grid. The created ions are collected by a 3-element lens-like configuration of anode-shield-reflector. The gauge is also based on the extractor geometry and has been modified to accommodate a new source of electrons called micro tips (see below). The reflector is a hemisphere of 8 mm radius with an apex aperture through which is mounted the collector (0.15 mm diameter 3

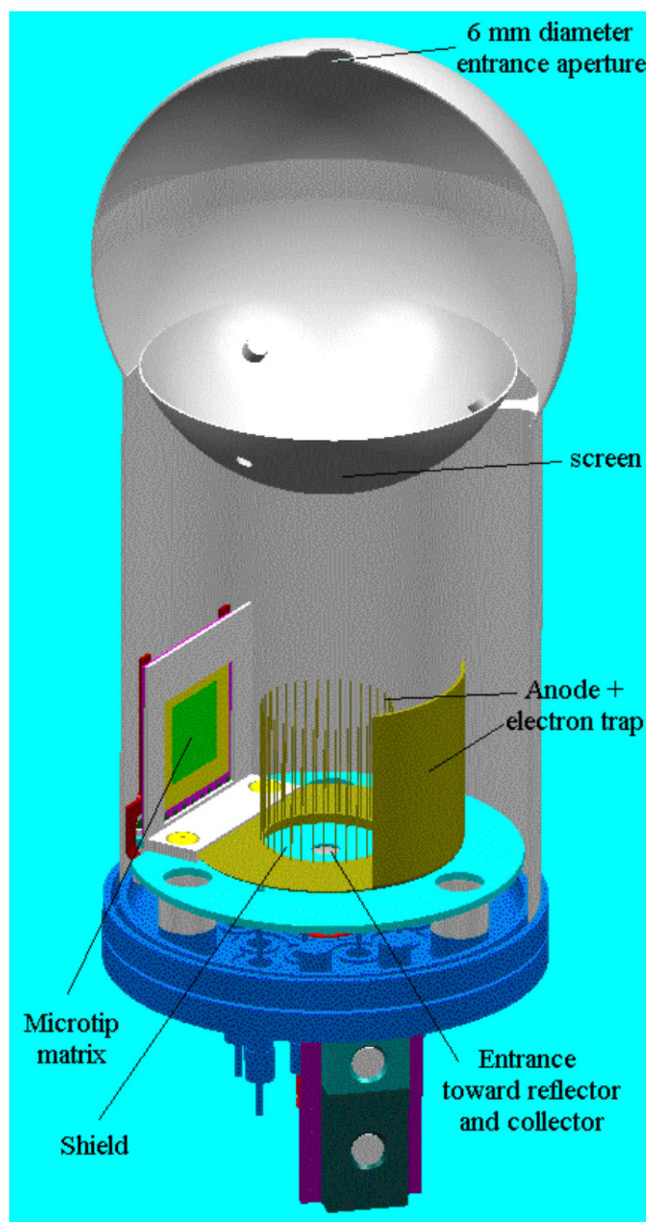

Fig. 1.25: Schematic of the Ram gauge

mm long). The anode (16 mm diameter 19 mm height) is at 180 V; the shield with an aperture of 3.4 mm diameter at its centre is at 0 V. The anode (16 mm diameter 19 mm height) is at 180 V. The sensitivity of the laboratory prototype is 5.0 mbar^{-1} for nitrogen and 5.8 mbar^{-1} for argon between 10^{-10} mbar and 10^{-4} mbar . The gauge should be able to measure down to 10^{-11} mbar . Tests in the Casimir showed the capability to measure gas speed. Micro tip field-emitter devices replaced the usual filament.

1.2.3.3 The microtips

The micro tips of the Spindt-type (Meyer 1966; Constancias 1998) were introduced into this type of set-up by Baptist et al. (1996). The micro tips have a resistive layer (Levine 1996) to increase emission stability and serve as ballast in case of arc generation. This type of micro-emitter is the only one in volume production for flat panel displays. The manufacturers claim a 20 000 h lifetime – much longer than for silicon tips and others. Tests are evaluating their resistance to the

cometary environment. The influence of O_2 and H_2 has already been studied (Temple 1999). The emitter is made of more than 1 800 000 tips arrayed in 32×32 pixels representing an emitting area of $14 \times 14 \text{ mm}$ (Fig. 26). The 1024 pixels were grouped by bonding onto a ceramic with gilded tracks in eight interlaced groups of



vertical lines. This arrangement gives eight independent emitters that can be addressed separately either sequentially or jointly. Each group can deliver 1 mA at 70 V extraction voltage (Fig. 27). For very low pressures several groups emit together. For higher pressures a pulsed mode or scanning mode is adopted. Possible redundancy is obvious and an improved resistive layer should emphasise this advantage. An advantage of this emitter is that no heat is generated unlike a filament. This is important because the gas temperature is not modified. Such an emitter is of particular interest for space applications because of its low power consumption.

1.2.3.4 Mechanical / Structure / Electronics

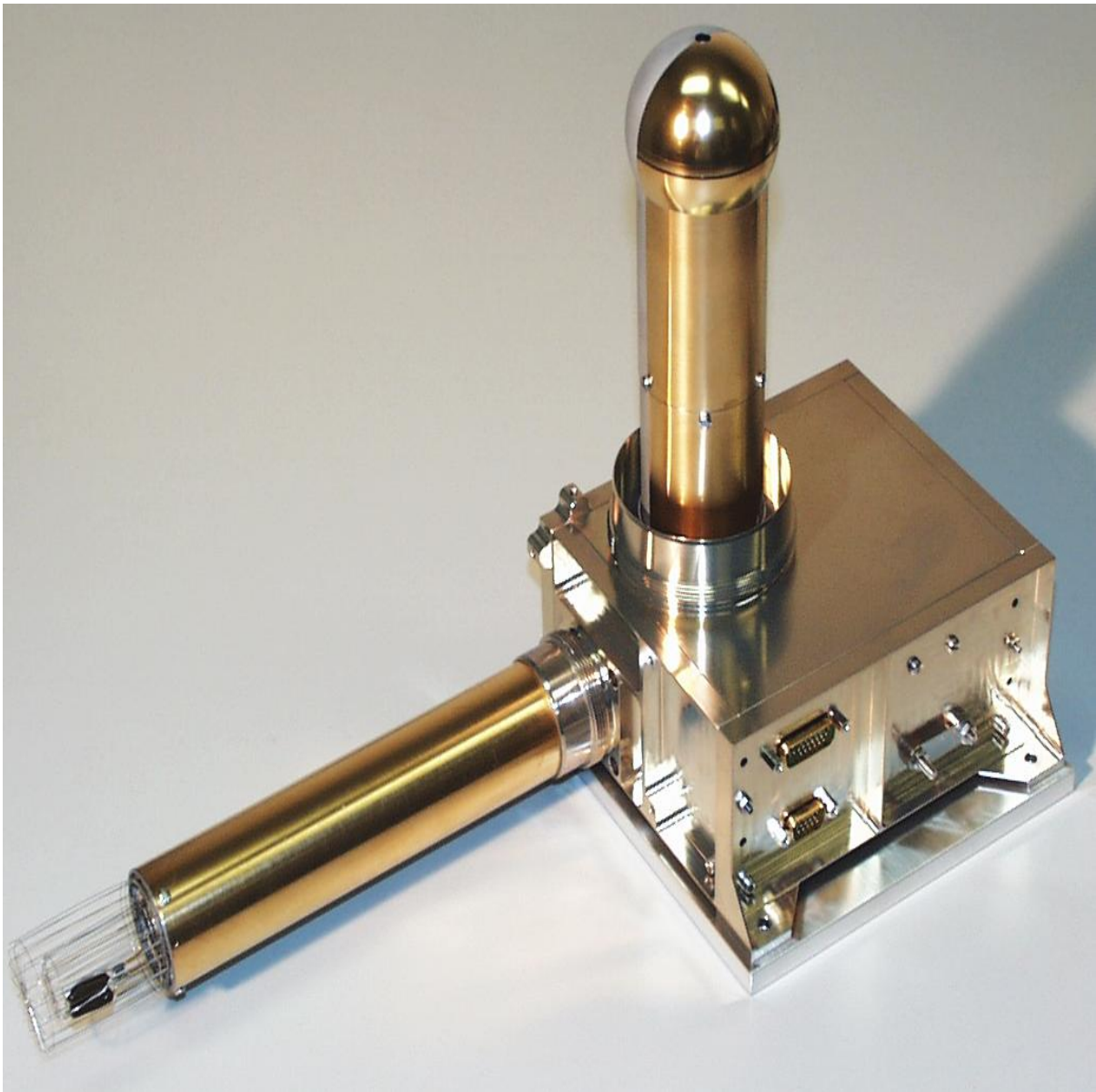

Fig. 1.26: COPS EQM



The nude and ram gauges are each mounted at the end of a boom (Fig. 28) to avoid direct gas reflections from the payload platform or the nearest instruments. For mechanical stiffness and accommodation for launch the booms are limited to lengths of 25 cm. In order to preserve cleanliness the gauges will be continuously purged with nitrogen until launch. The three electronic boards are housed in a 165×140×75 mm box that also supports the booms. The instrument mass is 1.5 kg. The digital board controls the link with ROSINA's controlling DPU. The second board contains high-voltage supply and control for the ram gauge plus two electrometers to measure the ion current of each gauge. Each electrometer has three ranges (10⁻¹ 100 M₊ with 1 μF integration capacitor) switched by the D U. The measured value is 12-bit digitised and the total range is 0.1 pA - 1 μA. The third board is dedicated to the power supplies for the nude gauge. The total nominal consumption is 7 Watt 28 V primary with 2400 mW for the nude gauge and 720 mW for the ram gauge (the difference lying in the ram gauge's newer technology). The ram gauge boom points toward the comet while the nude gauge boom is parallel to the solar panels. Half of COPS will never be exposed to the Sun so half of each boom is sandblasted and the other half is gold-plated. To avoid strong thermal gradient in the ram gauge (it would degrade the measurement), half of its boom is sandblasted and the other half is gold-plated. The electronics box is protected by multi-layer insulation.

1.2.4 DPU

1.2.4.1 DPU Hardware Design

Principal drivers of the DPU design are (a) optimum use of the allocated telemetry rate, (b) single failure tolerance for all functions serving more than one sensor, and (c) design not dependant on availability of radiation hardened parts.

The primary data rate of all three detectors exceeds the maximum S/C telemetry rate (20 kbps) by more than three orders of magnitude. Therefore, reduction of the scientific data is a basic task. It is performed in two levels: (1) H/W based integration within the sensor electronics, and (2) subsequent S/W processing as (i) spectrum windowing, (ii) averaging, resulting in degraded mass and/or time resolution, (iii) loss less compression (modified Rice PSI14), and task specific lossy compression. All S/W processing is done in the DPU by a 32-bit digital signal processor (DSP, TSC21020F) with a large amount of fast SRAM memory (3 Mbytes program, 8 Mbytes data memory). Fig. 1.19 shows an overall block diagram of the DPU.

All DPU functions are duplicated and organized into two independent (cold redundant) branches except (1) the three sensor interfaces and (2) the hard core for selection of the active branch. Cross strapping is applied between each sensor interface and each DPU branch, and between each DPU power converter and each DPU branch.

The program and data memory is H/W-protected against single event upsets (SEUs) and permanent device failures. For adaptation to 8-bit wide memory devices a "Single 8-bit Symbol Error Correction, Double 8-bit Symbol Error Detection" (48,72)-



Reed-Solomon Code is used. Periodic scrubbing of the memories acts against accumulation of non-correctable double symbol errors. Remaining SEU-induced undetected errors (> 2-symbol memory errors) can produce a breakdown of the program execution, which is monitored by a watchdog circuit.

Single event latch-up (SEL) induced overcurrents will be detected by current monitoring. 9 current monitors protect each of both DPU branches. If an overcurrent occurs, the DPU branch will be de-energized by a fast (μ s) current breaker.

1.2.4.2 DPU Software Design

The DPU S/W is based on the real-time multitasking operating system Virtuoso (Eonic Systems) that provides (1) preemptive, event-driven scheduling, (2) dynamically prioritized tasks, (3) synchronization and communication facilities (semaphores, mailboxes, queues, timers), (4) dynamic memory management, and (5) handling of multilevel device interrupts.

All S/W tasks are grouped in a layer model with 6 layers: (5) Scientific Software, (4) Operation Control (command execution, emergency mode, In-flight calibration, etc.), (3S) Service Functions (command interpreter, housekeeping collection, data compression, etc.), (3) Element Functions (detector on/off, data acquisition / handling, etc.), (2) Subelement Functions (direct control of subelements), and (1) Low Level S/W (H/W driver, I/O control).

1.2.4.3 Electrical Ground Support Equipment (EGSE)

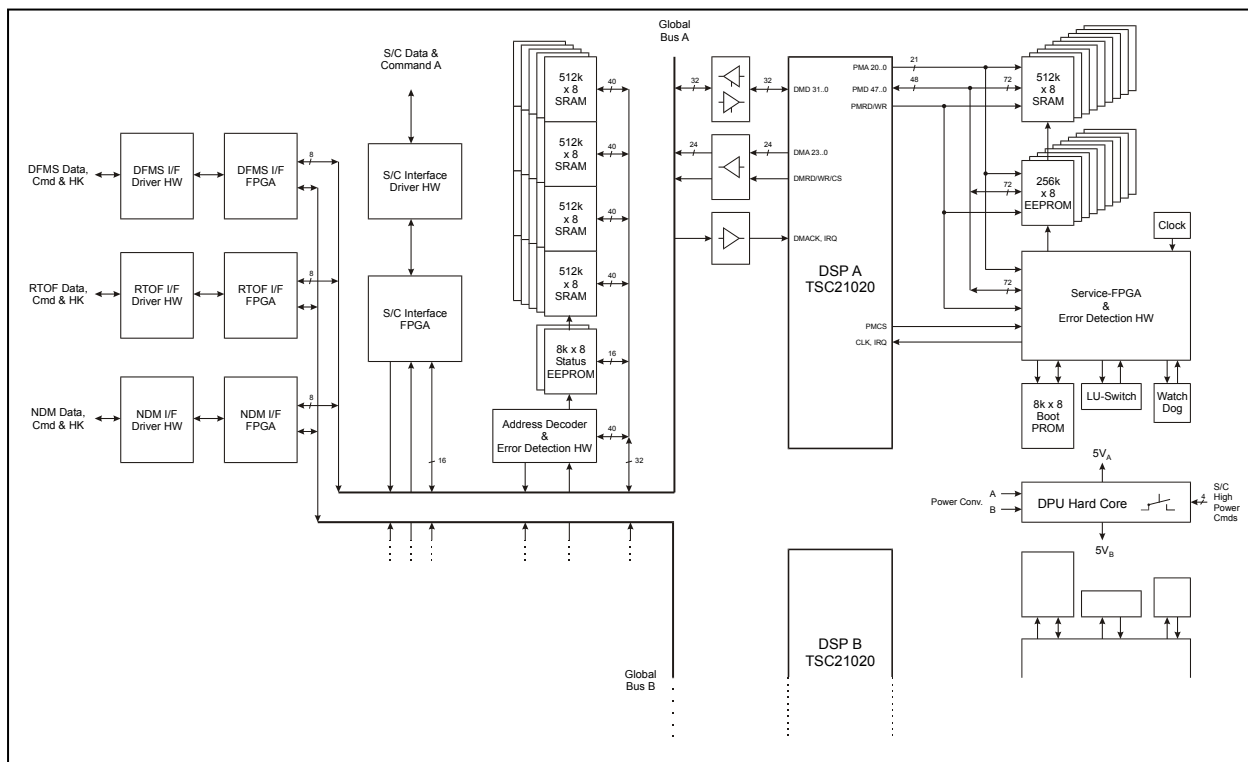



2.1.2 Mechanical Interface

2.1.2.1 Mechanical Interface Control Drawings

2.1.2.1.1 Double Focusing Mass Spectrometer (DFMS)

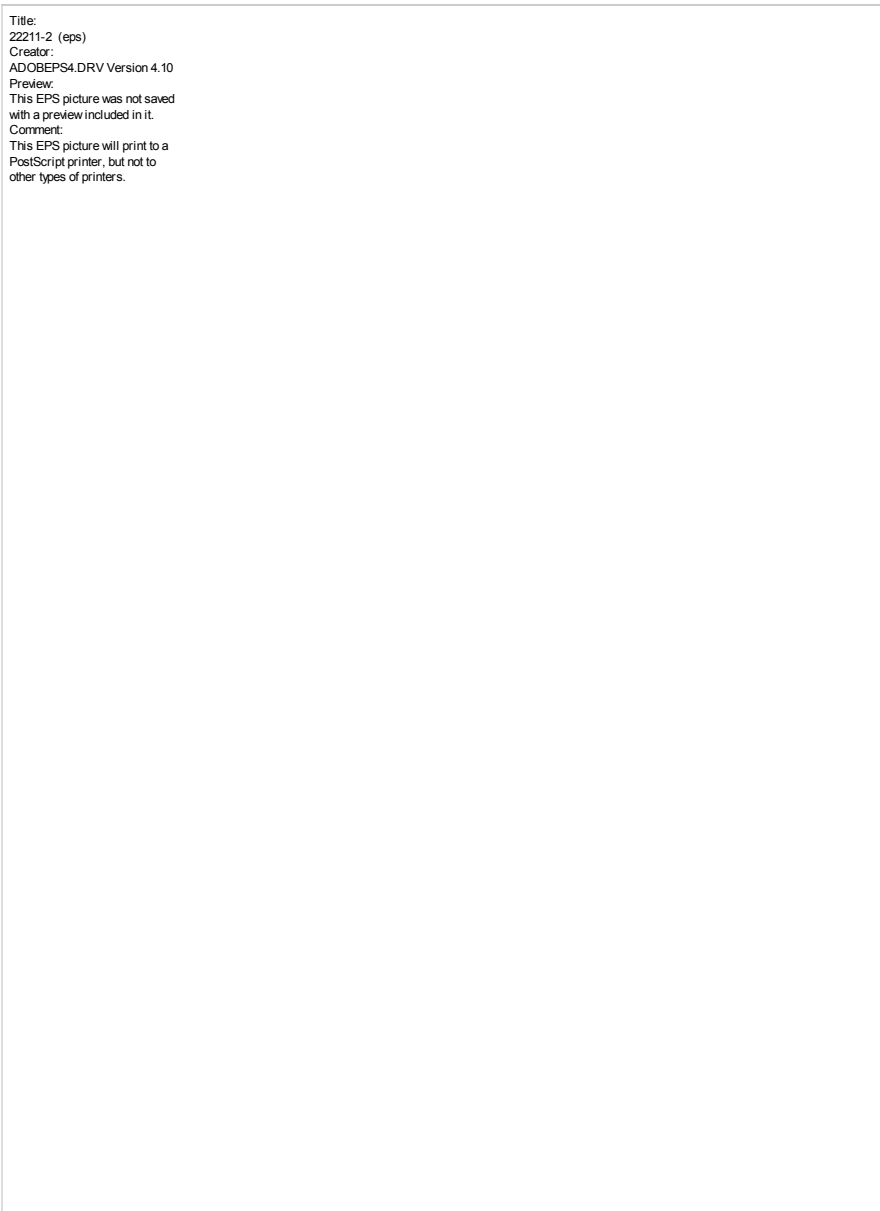

2.1.2.1.2

Figure 2. 1: *Three-dimensional view of DFMS in Launch Configuration*



Title:
22211-4 (eps)
Creator:
ADOBEPS4.DRV Version 4.10
Preview:
This EPS picture was not saved
with a preview included in it.
Comment:
This EPS picture will print to a
PostScript printer, but not to
other types of printers.

*Fig. 2.2.2.1.1-2: Mechanical Interface Control Drawing of DFMS
in Launch Configuration (UoB Drawing M155-1001)*



Rosetta ROSINA

Reference : **RO-ROS-Man-1009**
Issue : **3** Rev. : **0**
Date : 26.04.19
Section : 2 Page : **50**



Figure 2.3 The dimensional view of DFMS in Operating

Configuration)



Rosetta ROSINA

Reference : **RO-ROS-Man-1009**
Issue : **3** Rev. : **0**
Date : 26.04.19
Section : 2 Page : **51**



Fig. 2. 4: Mechanical Interface Control drawing of DFMS in Operating Configuration (UoB Drawing M155-1004)



2.1.2.1.3 Reflectron Time of Flight Spectrometer

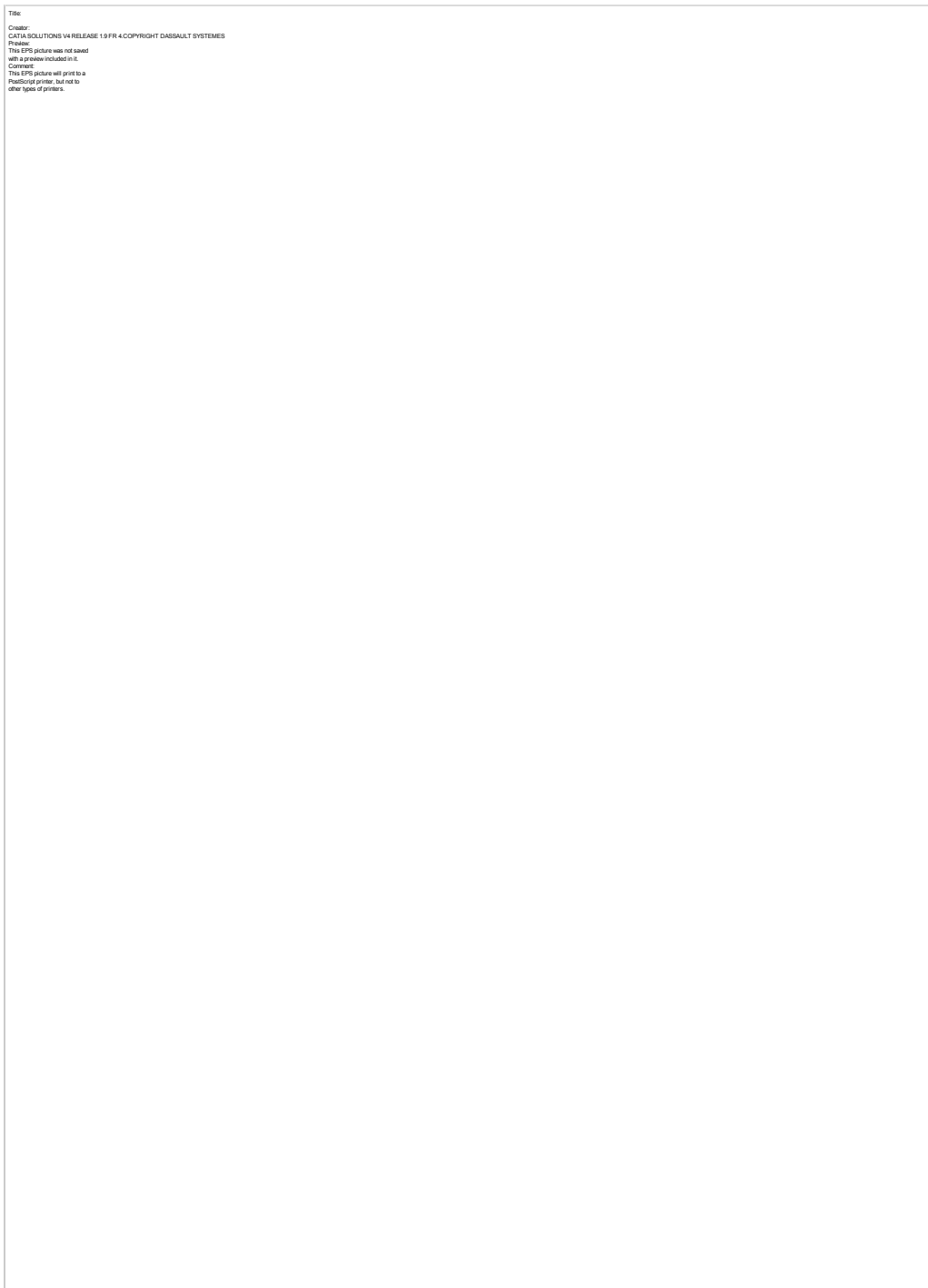

Figure 2.5

Three-dimensional view of RTOF in Launch Configuration

Note: The pump-off valve will be removed respectively pinched off before launch.



Title:
22212-2 (eps)
Creator:
ADOBEPS4.DRV Version 4.10
Preview:
This EPS picture was not saved
with a preview included in it.
Comment:
This EPS picture will print to a
PostScript printer, but not to
other types of printers.

*Fig. 2.6:
Mechanical Interface Control Drawing of RTOF in Launch Configuration (UoB Drawing M156-1002)*



Rosetta ROSINA

Reference : **RO-ROS-Man-1009**
Issue : **3** Rev. : **0**
Date : 26.04.19
Section : 2 Page : **54**

Title:
Creator:
CATA SOLUTIONS V4 RELEASE 1.9 FR 4 COPYRIGHT DASSAULT SYSTEMES
Provider:
This EPS picture was not saved
with a profile included in it.
Comment:
This EPS picture will print to a
PostScript printer, but not to
other types of printers.

Figure 2.7

Three-dimensional view of RTOF in Operating



Configuration

Title:
22212-4 (eps)
Creator:
ADOBEPS4.DRV Version 4.10
Preview:
This EPS picture was not saved
with a preview included in it.
Comment:
This EPS picture will print to a
PostScript printer, but not to
other types of printers.

Fig. 2.8: Mechanical Interface Drawing of RTOF in Operating Configuration (UoB Drawing M156-1003)



2.1.2.1.4 Comet Pressure Sensor

Title:

Creator:
CATIA SOLUTIONS V4 RELEASE 1.9 FR 4.COPYRIGHT DASSAULT SYSTEMES

Preview:

This EPS picture was not saved
with a preview included in it.

Comment:

This EPS picture will print to a
PostScript printer, but not to
other types of printers.

Fig. 2.9: 3 dimensional view of the COPS sensor



Rosetta ROSINA

Reference : **RO-ROS-Man-1009**
Issue : **3** Rev. : **0**
Date : 26.04.19
Section : 2 Page : **57**

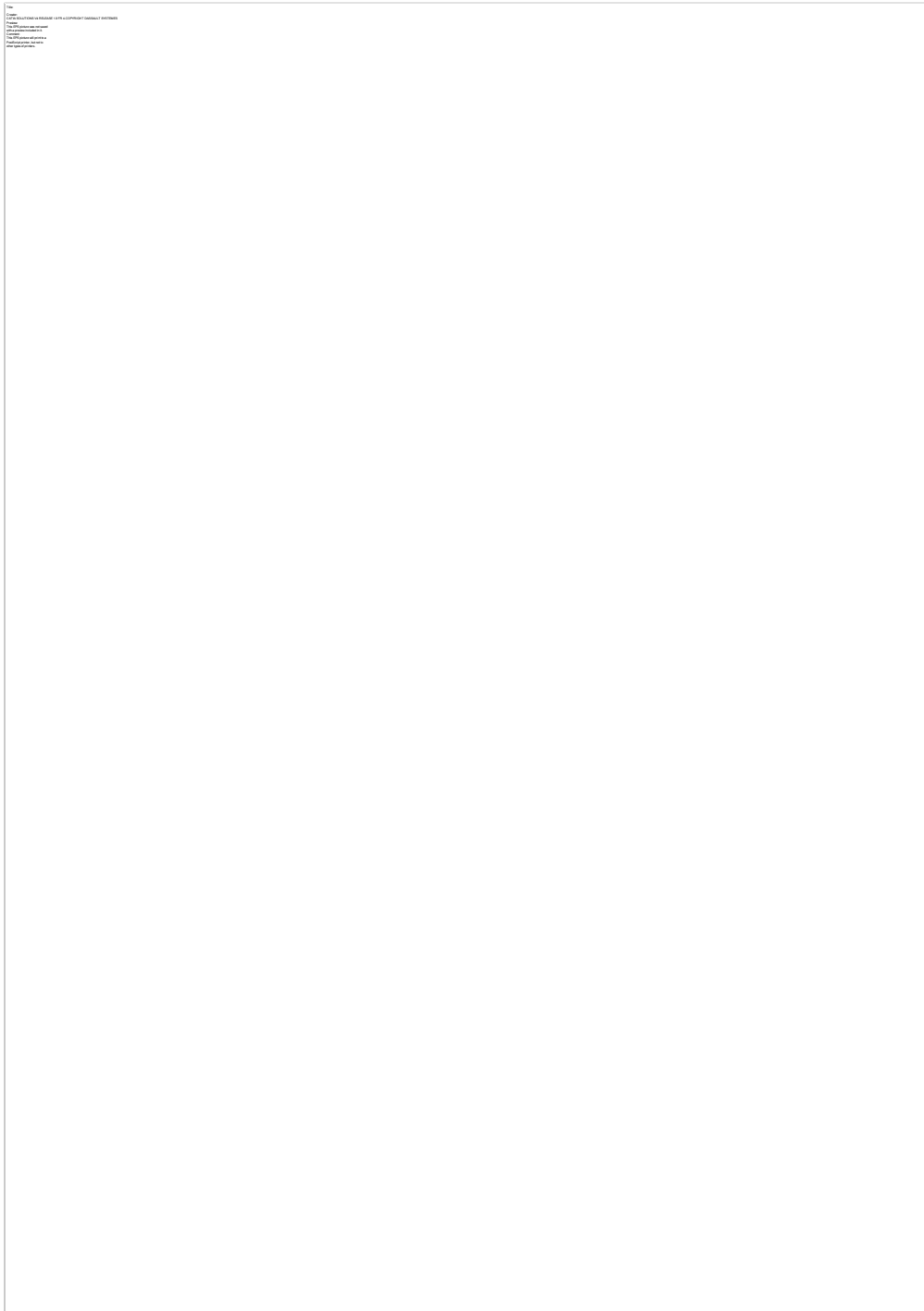

*Figure 2.10 Mechanical Interface Control drawing of COPS
(UoB Drawing M158-1001)*



2.1.2.1.5 Data Processing Unit (DPU)

This EPS picture will print to a PostScript printer, but not to other types of printers.

2.11 Three-dimensional view of the

Figure



Rosetta ROSINA

Reference : **RO-ROS-Man-1009**
Issue : **3** Rev. : **0**
Date : 26.04.19
Section : 2 Page : **59**



DPU

Figure 2.12

*Mechanical Interface Control Drawing of the DPU
(UoB Drawing M157-1000)*



2.2 Electrical

2.2.1 General

Each 28 V MAIN BUS supply comprises 2 supply wires and 2 return wires for each main and redundant I/F respectively, see Table 2.1

Function	Number of Main Lines Required	Number of Redundant Lines Required	LCL Class
+ 28 V MAIN BUS (Switched and Current limited)	1	1	E (109 W / 4.0 A trip-off limit)
+ 28 V NON-OPS. HEATER POWER for DFMS (Switched and Current limited)	1	1	B (22 W / 0.8 A trip-off limit)
Converter Synchronisation Signal	0	0	
Keep-Alive Supply	0	0	

2.2.2 Power Distribution and Redundancy Scheme

Each major subassembly has its own power converter controlled by the DPU. The DPU has redundant power converters (Fig. 2.13).

Both 28 V lines are routed to both DPU converters and (via the intra-instrument harness) to all three sensors.

In each of the sensors units, each the 28V-line and the Redundant-line have its own electronic switch, which is controlled by the DPU. Additionally to the switch, there is a current limiter circuit.

After that, at the inputs of the non-redundant power converter boards, the redundant power lines are electrically 'OR'ed, i.e. duplication protects against broken wires/connections only.



Rosetta ROSINA

Reference : **RO-ROS-Man-1009**
 Issue : **3** Rev. : **0**
 Date : 26.04.19
 Section : 2 Page : **61**

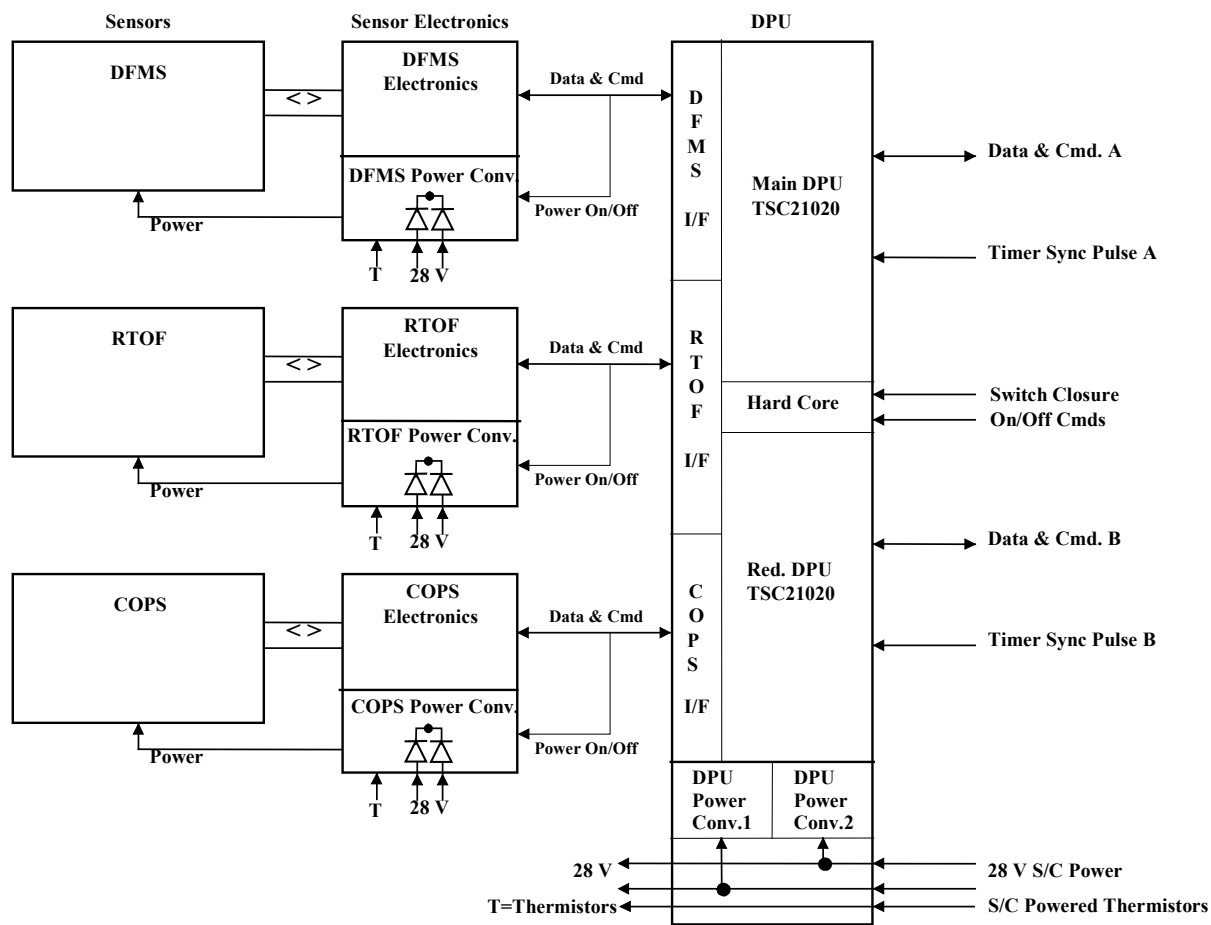

Fig. 2.13: Power and Harness Distribution



2.2.3 Experiment Power Requirements

Ref. to Sec. 4 for a description of ROSINA modes and for the respective power requirements.

Fig. 2.14: General Sensor Primary Power Switch

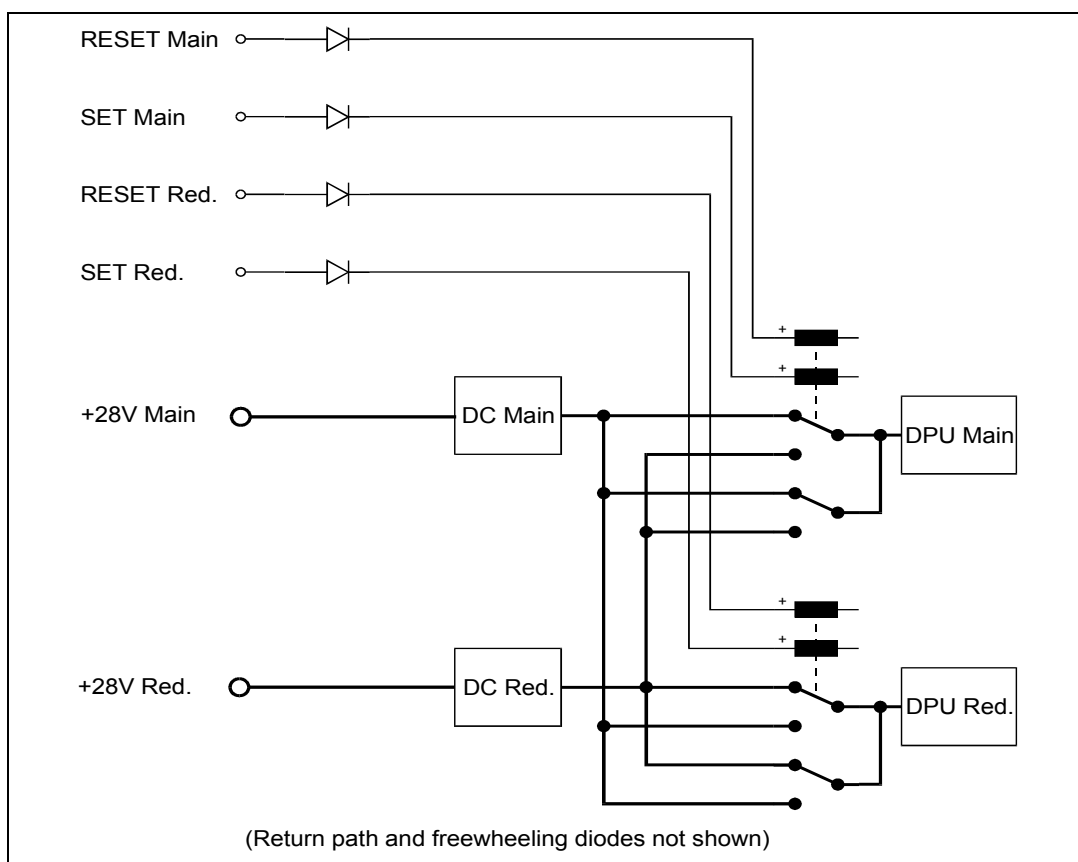

Fig. 215: DPU Power Switching Block Diagram



Rosetta ROSINA

Reference : **RO-ROS-Man-1009**
 Issue : **3** Rev. : **0**
 Date : 26.04.19
 Section : 2 Page : **63**

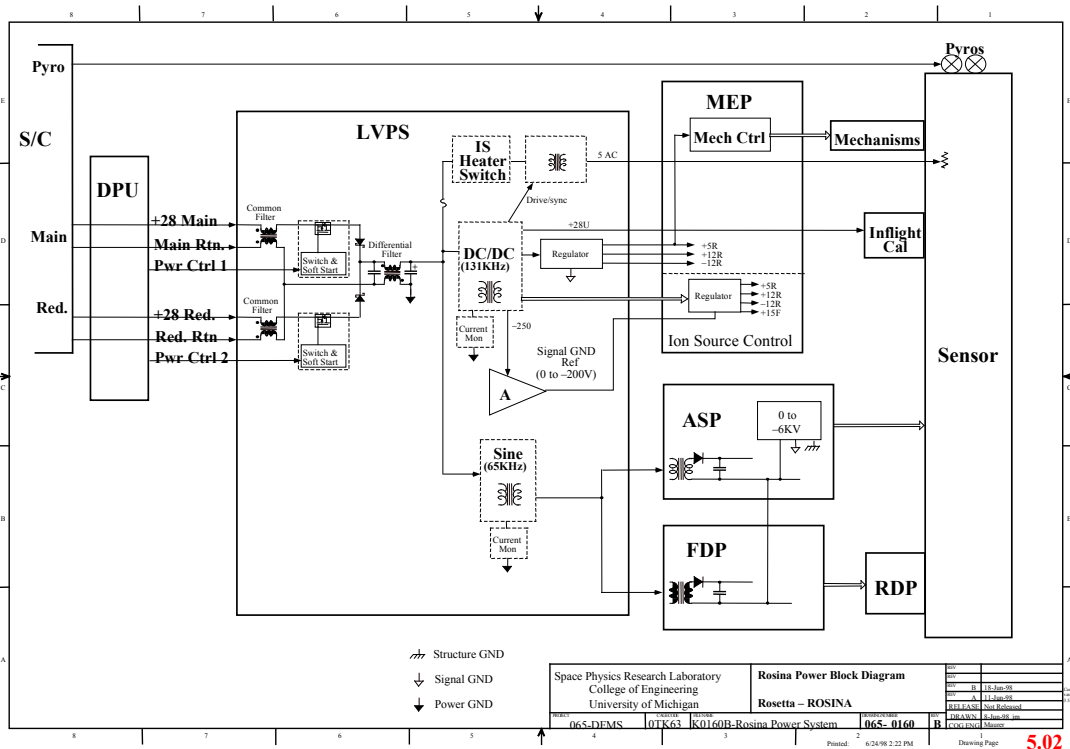

Fig. 2.16: DFMS Power Switching Block Diagram

DFMS/Interface Data Sheet	
Maximum Input Current	46.0/28V = 1.64A
Switch on: Inrush: Input Voltage: Inrush current after 8msec:	< 1A/μsec 25V-32V 1A/μsec*8msec >= 0.8A
Bus Isolation: +28V&28V-Ret/SignalGround:	>1MΩ/>5nF
Switch on/off:	Z35V-Zenerdiode as freewheeling
Noise Emission/Suseptibility:	EMC-Requirements and Suseptibility Requirements are kept by the provision of Common Mode Noise and Conducted Noise Filtering.

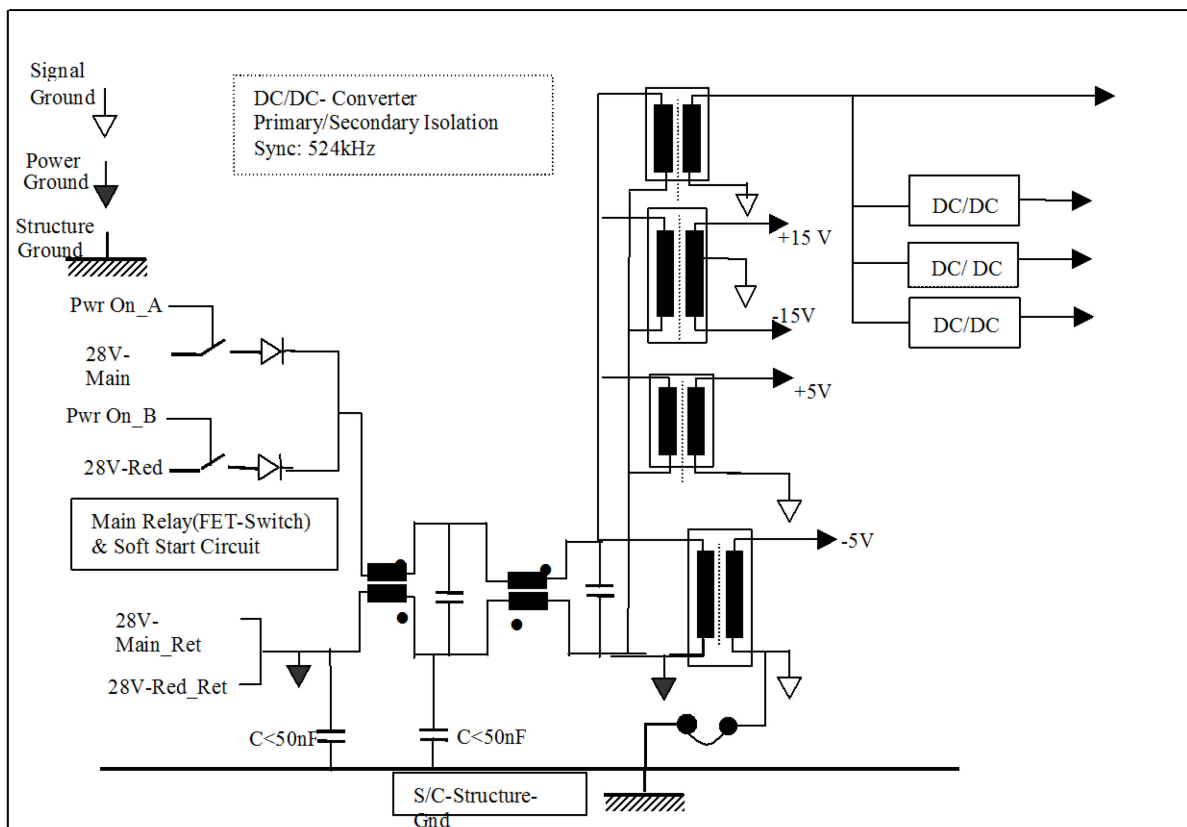

Fig. 2.17: RTOF Power Switching Block Diagram

RTOF/Interface Data Sheet	
Maximum Input Current	$44.6/28V = 1.6A$
Switch on: Inrush: Input Voltage: Inrush current after 8msec:	$1A/\mu\text{sec}$ 25V-32V $1A/\mu\text{sec} * 8\text{msec} \geq 0.8A$
Bus Isolation: +28V&28V-Ret/SignalGround:	>1M Ω />5nF
Switch on/off:	Z35V-Zenerdiode as freewheeling
Noise Emission/Suseptibility:	EMC-Requirements and Suseptibility Requirements are kept by the provision of Common Mode Noise and Conducted Noise Filtering.

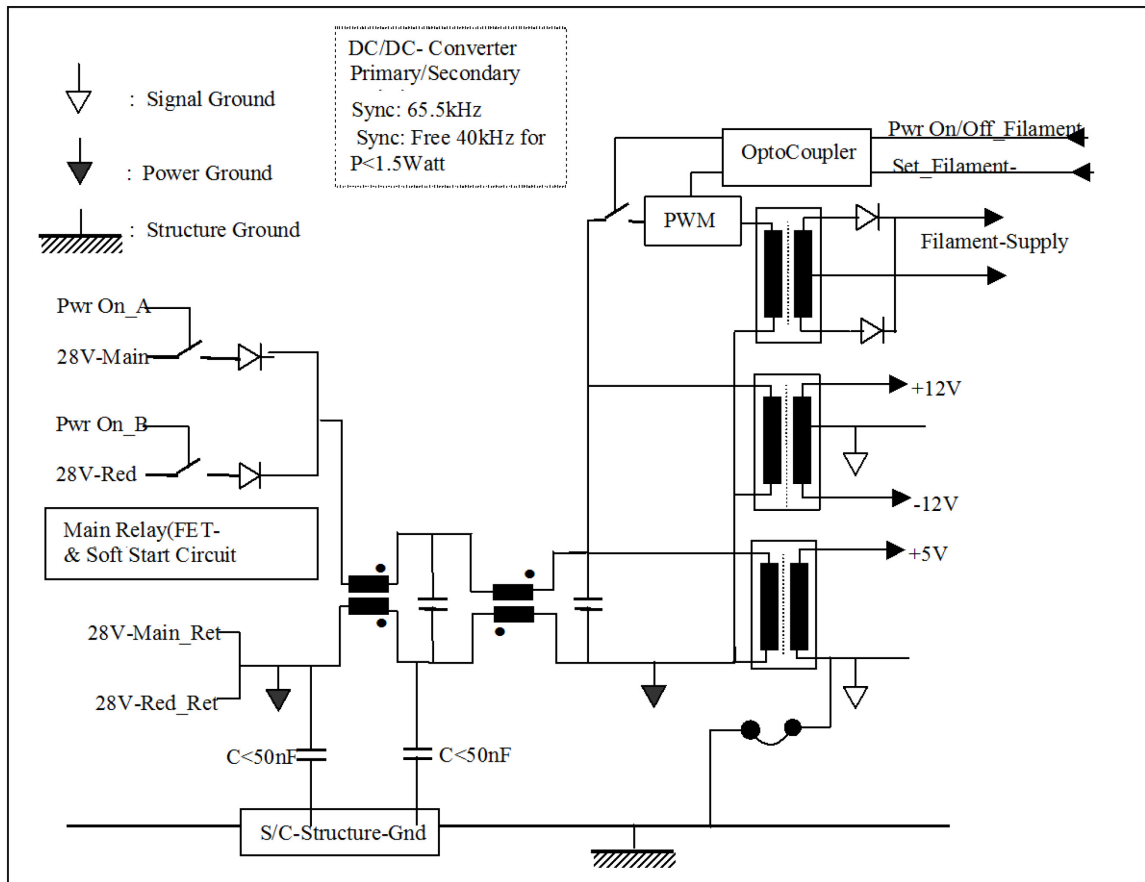

Fig. 2.18: COPS Power Switching Block Diagram

COPS/Interface Data Sheet	
Maximum Input Current	$7\text{W}/28\text{V} = 0.25\text{A}$
Switch on: Inrush: Input Voltage: Inrush current after 8msec:	<math>< 1\text{A}/\mu\text{sec}</math> 25V-32V $1\text{A}/\mu\text{sec} * 8\text{msec} \geq 0.8\text{A}$
Bus Isolation: +28V&28V-Ret/SignalGround:	>1M Ω >5nF
Switch on/off:	Z35V-Zenerdiode as freewheeling
Noise Emission/Suseptibility:	EMC-Requirements and Suseptibility Requirements will be kept by the provision of Common Mode Noise and Conducted Noise Filtering.
Impedance:	$28\text{V}/0.22\text{A} = 112\ \Omega$



2.2.4 PYROTECHNIC INTERFACE REQUIREMENTS

2.2.4.1 General Interface Description

Rosina has two different Electro Explosive Devices on the cover opening mechanism on each of the sensor units DFMS and RTOF. The Pyrotechnical Separation System breaks the vacuum sealing between the cover and the instrument and will be activated shortly after launch. Upon separation, the cover can be moved freely open and close by the commandable cover mechanism drive on the hinge. The Cover Pyro Detonator has two redundant ignition blocks and therefore needs a redundant wiring scheme.

The Cover Bellow Actuator is a fail-safe provision for the cover mechanism, which only will be activated in case of a cover mechanism failure, whereby the cover is released into a final open position. Because this actuator acts as a backup, there is only one, non-redundant actuator used.

Function	Number of Main Lines Required	Number of Redundant Lines Required
Open DFMS Vacuum Seal Entrance Aperture	1	1
DFMS Cover fail-safe actuator	1	0
Open RTOF Vacuum Seal	1	1
RTOF Cover fail-safe actuator	1	0

Table 2.5-1 PEU Firing Lines Requirements

Function	Initiator Principle	Power supplied by (if applicable)
No alternate Initiators used	N/A	N/A

Table 2.5-2: Alternate Initiators Function and Supply



2.2.4.2 Pyrotechnic Firing Line (PYR) Interface

The following drawings show the Pyrotechnical Interfaces of the S/C to the two sensor units DFMS and RTOF.

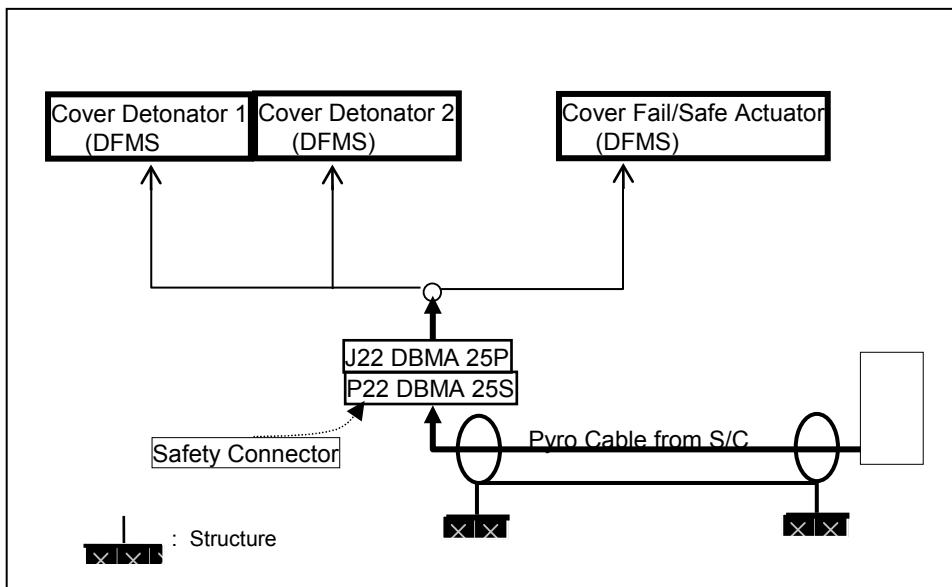

Fig.. 2.19: Pyrotechnical I/F of the S/C to the DFMS sensor.

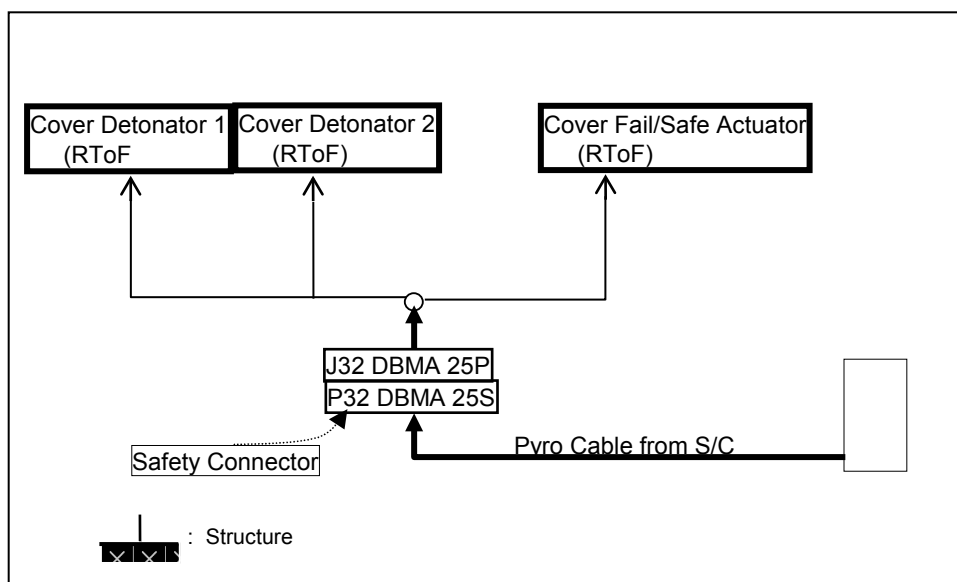

Fig. 2.20: Pyrotechnical I/F of the S/C to the RTOF sensor.



The characteristics of the Pyrotechnic Initiators are compiled in the following tables:

Pyrotechnic Initiator for the Cover Separation System PEU Load Interface Specification and Mechanical Characteristics	
Pyro Type:	1 DPWH 30 -Detonator
Manufacturer:	Dassault
Procurement Specification:	FICHE E1/02
Electrical Characteristics:	
Bridge Resistance:	1.05 +/- 0.15 Ohm
All Fire Condition: (Current and Pulse Duration)	4 A, >10ms <20msec
No Fire Current: (Current and Pulse Duration)	1 A, 5 min.
Insulation Resistance between filaments and EED case before and after Firing:	> 100 MOhm
Electrostatic Discharge Strength: (inc. Conditions)	25'000 V (500 pF, 5 KOhm)
Operating and Non-Op Temperature Range: Storage Temperature Range:	-90 °C / +100 °C +10 °C / +30 °C
Mechanical Characteristics:	
Mass:	< 14 g
Maximum mass of Explosives:	70mg(40mg AW1 + 30mg RDX)
Dimensions:	diameter 14 mm, length 35.7 mm

Table 2.5-3: Pyrotechnic Device Interface Characteristics,
Cover Separation Function



Pyrotechnic Initiator for the Cover Bellow Actuator PEU Load Interface Specification and Mechanical Characteristics	
Pyro Type:	MARK20 MOD 0
Manufacturer:	Quantic Industries
Procurement Specification:	PN 1379 AS 781
Electrical Characteristics:	
Bridge Resistance:	1.0 +-0.15 Ohm *)
All Fire Condition: (Current and Pulse Duration)	4A < 20msec *)
No Fire Current: (Current and Pulse Duration)	1 A, 5min *)
Insulation Resistance between filaments and EED case before Firing:	> 100 MOhm @ 500 V DC before, short circuit expected after firing 25000V (500pF, 5KOhm)
Electrostatic Discharge Strength: (inc. Conditions)	-54 °C, +74 °C
Operating and Non-Op Temperature Range: Storage Temperature Range:	-54 °C / +54 °C
Mechanical Characteristics:	
Mass:	< 5g
Maximum mass of Explosives:	61 mg Black powder
Dimensions:	diameter 7.7mm x 25.5mm

*) The electrical parameters for the Initiator are being adjusted by an additional passive matching network.

Comprehensive Qualification and Functional Tests under audit will be performed.

Table 2.5-4: Pyrotechnic Device Interface of the
Cover Bellow Actuator



2.2.5 Thermal Interfaces

There are several drivers which determine the thermal requirement of ROSINA:

1. The operating temperature of the detectors of all three sensors has to be between -30° C and +30° C.
2. The ion sources of the two mass analysers DFMS and RTOF should be warmer, or at least not colder than the other experiments on the platform or the platform itself (contamination).
3. No temperature gradient in the sensors and stable temperatures for several measurement cycles (several minutes).

Experiment Unit/Subsystem	Operating Temperature		Nonoperating Temperature		Switch-on Temperature	
	min	max.	min	max.	min	max.
DFMS Sensor	-30°C	50°C	-50°C	60°C	-30°C	50°C
DFMS Detector	-40°C	40°C	-50°C	60°C	-40°C	40°C
Cover separation pyrocord	+10°C	+30°C	-90°C	+100°C	+10°C	+30°C
Cover fail safe mechanism	-54°C	+74°C	-54°C	+74°C	-54°C	+74°C
DFMS Electronics	-30°C	50°C	-50°C	60°C	-30°C	50°C
RTOF Sensor	-30°C	50°C	-50°C	60°C	-30°C	50°C
RTOF Detector	-20°C	40°C	-50°C	60°C	-20°C	40°C
Cover separation pyrocord	+10°C	+30°C	-90°C	+100°C	+10°C	+30°C
Cover fail safe mechanism	-54°C	+74°C	-54°C	+74°C	-54°C	+74°C
RTOF Electronics	-30°C	50°C	-50°C	60°C	-30°C	50°C
COPS Sensor	-30°C	50°C	-50°C	60°C	-30°C	50°C
COPS Electronics	-30°C	50°C	-50°C	60°C	-30°C	50°C
DPU	-20°C	50°C	-50°C	60°C	-20°C	50°C

Table 2.2.5-1 ROSINA temperature requirements

The critical areas of DFMS and RTOF driving the thermal design are defined in the two drawings below.



— OPERATING TEMP.
— NON OPERATING "

TEMPERATURE CRITICAL ELEMENTS DFMS

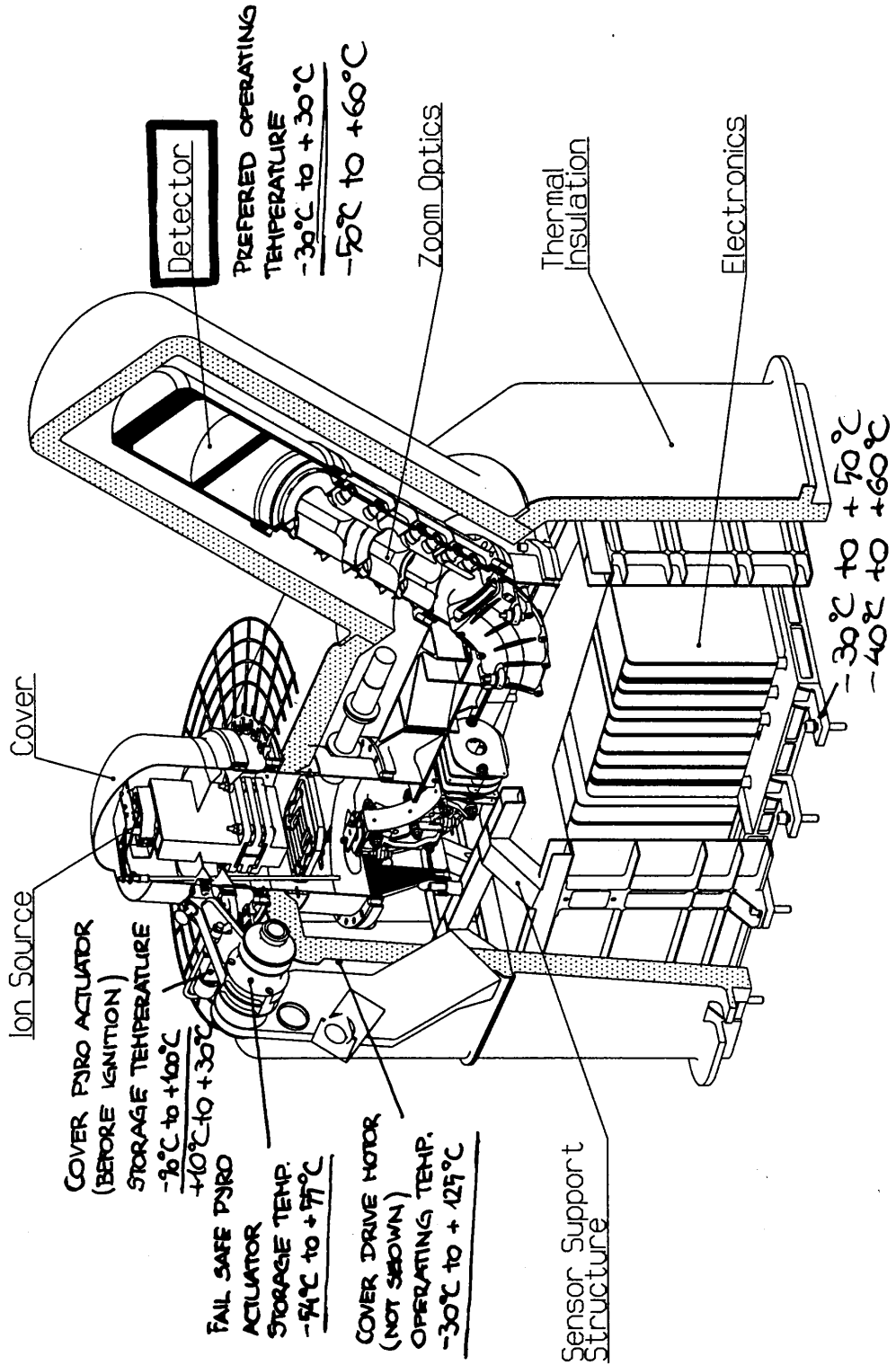

Illustrative sketch only, for internal temperature limits ref. to Table 2.2.5-1



Rosetta ROSINA

Reference : RO-ROS-Man-1009

Issue : 3 Rev. : 0

Date : 26.04.19

Section : 2 Page : 72

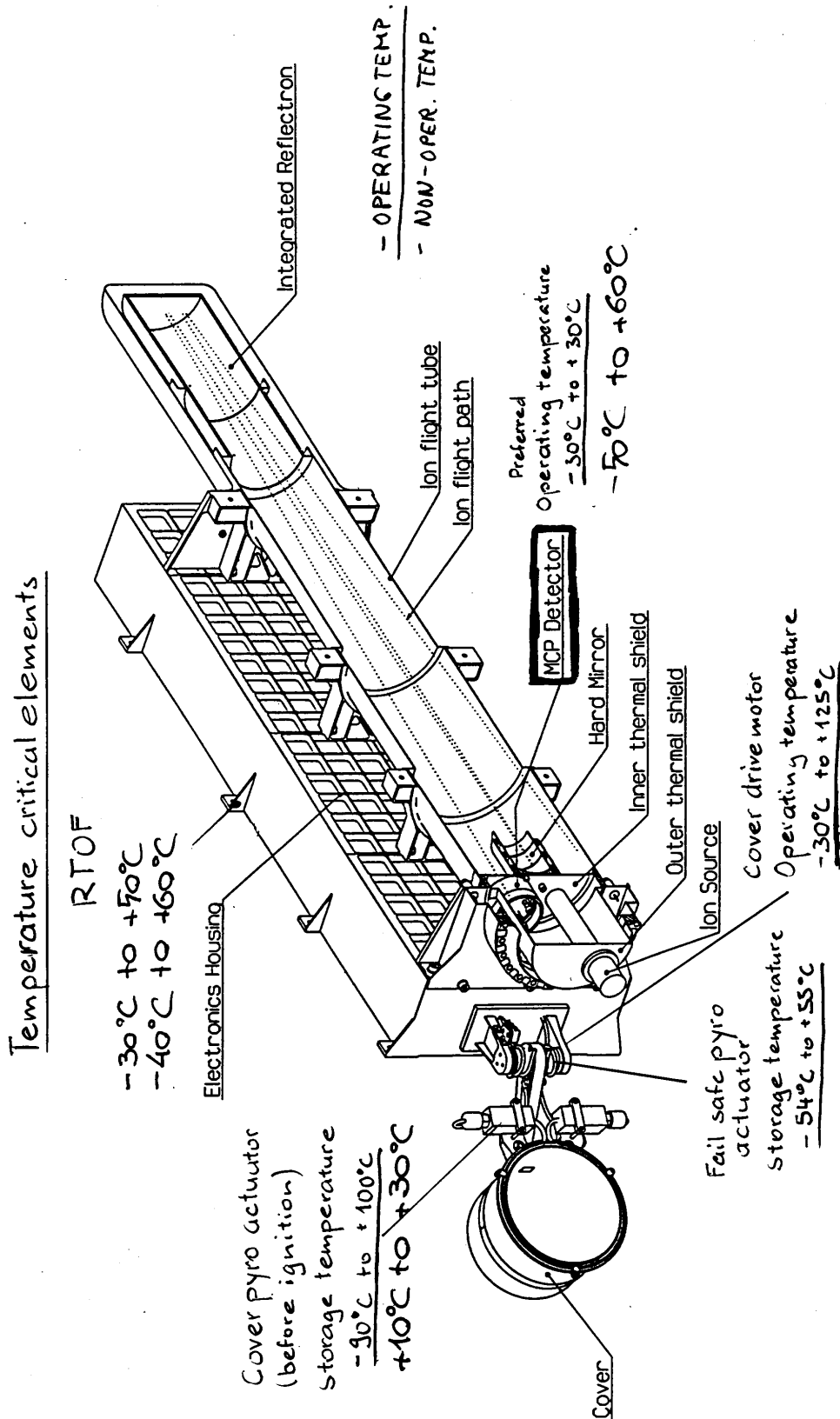

Illustrative sketch only, for internal temperature limits ref. to Table 2.2.5-1



2.2.6 OBDH INTERFACE REQUIREMENTS

2.2.6.1 Channel Allocation

Interface	Signal Type or Function	Main	Redundant
Telecommand Channels	Memory Load Commands	1	1
	High Power ON/OFF Commands	2	2
Telemetry Channels	16 Bit Serial Digital Channel	1	1
	Fast Serial Interface	N/A	N/A
Monitor Channels	Spacecraft Powered Thermistors	3	2
	Bi-level Channels	0	0
	Analogue Channels	0	0
Timing Channels	High Frequency Clock	0	0
	Timer Sync Pulse	1	1

Table 2.7-1: Experiment OBDH Interface Channels/Functions

Functional Description of OBDH Channels:

High Power ON/OFF Commands:

Two channels are needed for switching between the main and redundant DPU branches.

Spacecraft Powered Thermistors:

One thermistor for each DFMS, RTOF (both redundant) and COPS (non-redundant) is needed to monitor the temperature, when the instrument is off.

Other Channels: Standard function according to EID-A.



2.2.6.2 Bit Rate Requirements

The data collection rate of the ROSINA instrument is continuous and occurs at a bit rate of > 1 Mbps which is far too high to be transmitted. It is therefore foreseen to reduce the data stream in the instrument.

The reduction is performed on two levels:

1. H/W based integration within accumulation memories of 32k...64 k channels.
2. S/W processing as
 - (i) spectrum windowing,
 - (ii) averaging resulting in degraded mass and/or time resolution, (iii) lossless compression (SPIHT wavelet),and in case of low telemetry rates - task specific lossy compression.

The level-1 H/W is part of the sensor electronics.

Depending on the scientific task (continuous monitoring, characterisation of outbursts and jets, etc.) and the available rate and time for data transmission the bit rate of the DPU to the spacecraft can be adjusted between 200 bps and 4000 bps continuous data flow (between 17 Mbit and 350 Mbit per day).

2.2.6.3 Timing

Ref. to sec. 2.8, ROSINA has no particular requirements on the timing wrt. UTC.

2.2.6.4 Monitoring

Ref. to sec. 2.8.



2.2.6.5 Electrical Interface Circuits

The OBDH interface will be according to EID-A chapter 2.7 using the driver and receiver circuits in figure 2.7.3-1 to 2.7.3-4. No cross coupling between redundant drivers and redundant processing units is foreseen inside the DPU.

The SBDL interface receiver circuit in figure 2.7.3-1 is used for the signals TC Sampling, TC Data, TC/TM Clock, TM Sampling and Timer Sync Pulse (main and redundant).

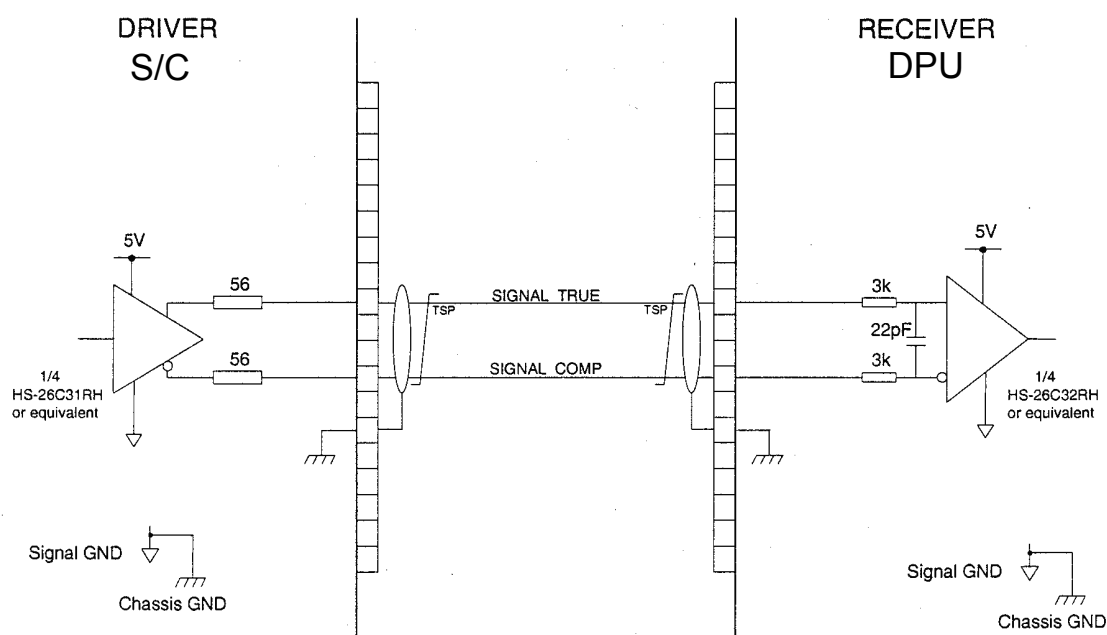

Fig. 2.22: SBDL Interface Receiver Circuit



The SBDL interface driver circuit in figure 2.23 is used for the signal TM Data (main and redundant).

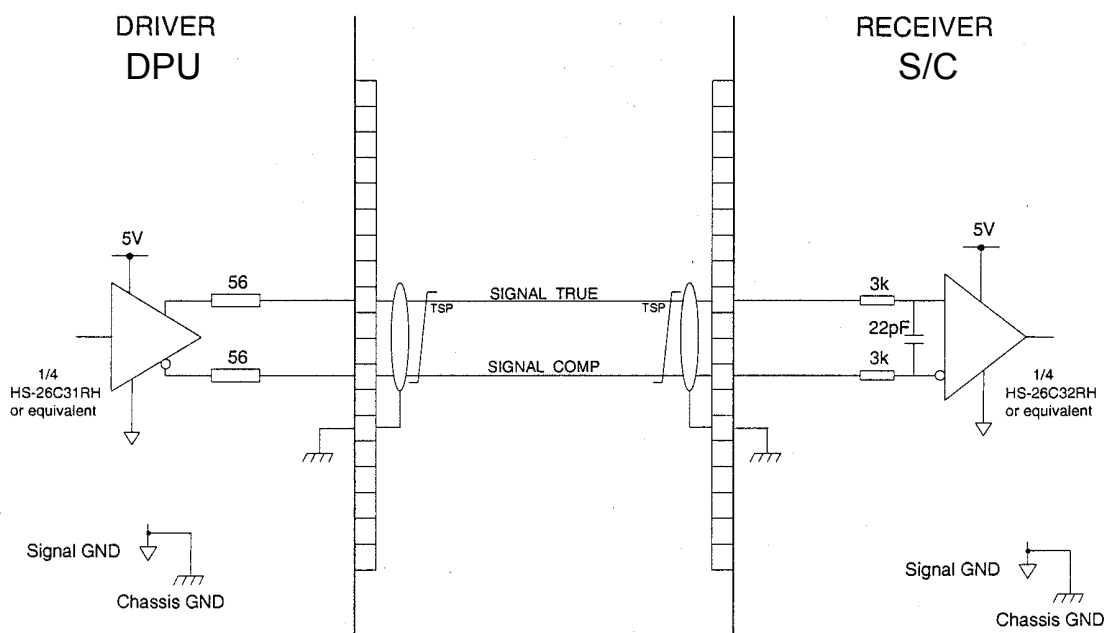

Fig. 2.23: SBDL Interface Driver Circuit



The high power ON/OFF command interface receiver circuit in figure 2.24 is used for the signals High Power Set and High Power Reset (main and redundant).

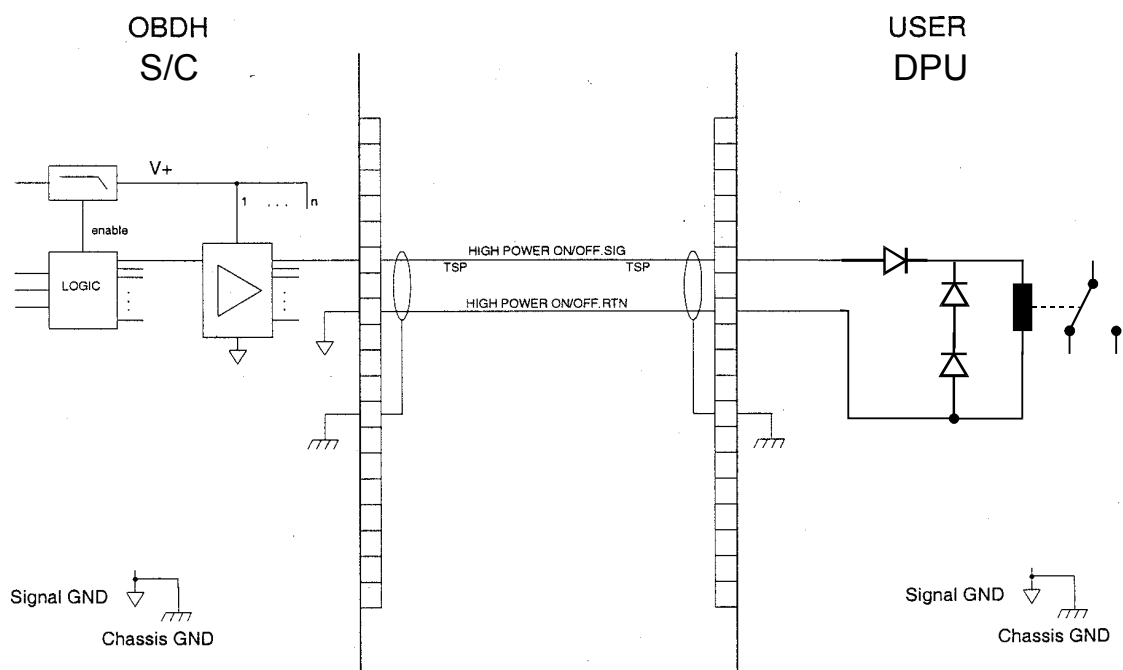

Fig. 2.24: High Power ON/OFF Command Receiver Circuit



The conditioned analogue thermistor interface circuit in figure 2.25 is used for the signals Thermistor 1, Thermistor 2, and Thermistor 3 (main and redundant).

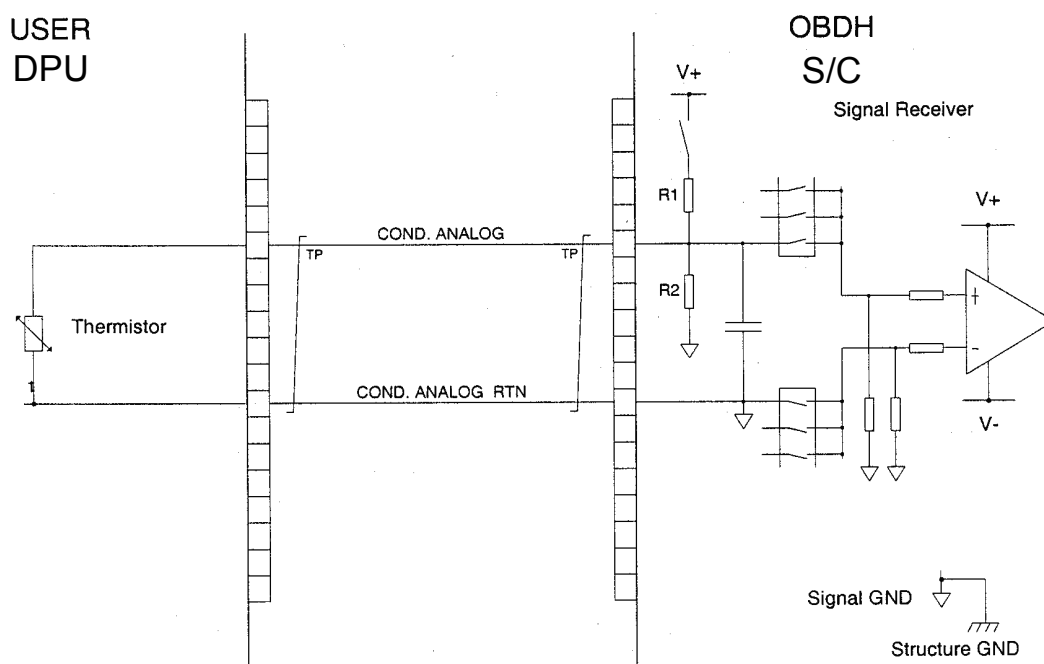

Fig. 2.25: Conditioned Analogue Interface Circuit



2.3 Software

2.3.1 Software Concept and Functional Requirements

2.3.1.1 Software Overview

The DPU S/W is based on a real-time multitasking kernel. ROSINA uses the Virtuoso SP (Eonic Systems) that provides

- (1) preemptive, event-driven scheduling,
- (2) dynamically prioritised tasks,
- (3) synchronisation and communication facilities (semaphores, mailboxes, queues, timers),
- (4) dynamic memory management, and
- (5) handling of multilevel device interrupts.

Fast interrupt routines (Low Level S/W) serve as the front line to the H/W, the data processing is done by dedicated S/W tasks. The S/W tasks including the operating system will be represented by 6 levels, from bottom (level 1) to top (level 5). Figure 2.8.1.1-1 shows the structure of the lowest two levels 0 and 1 and the structure of the application S/W located in level 2 and up:

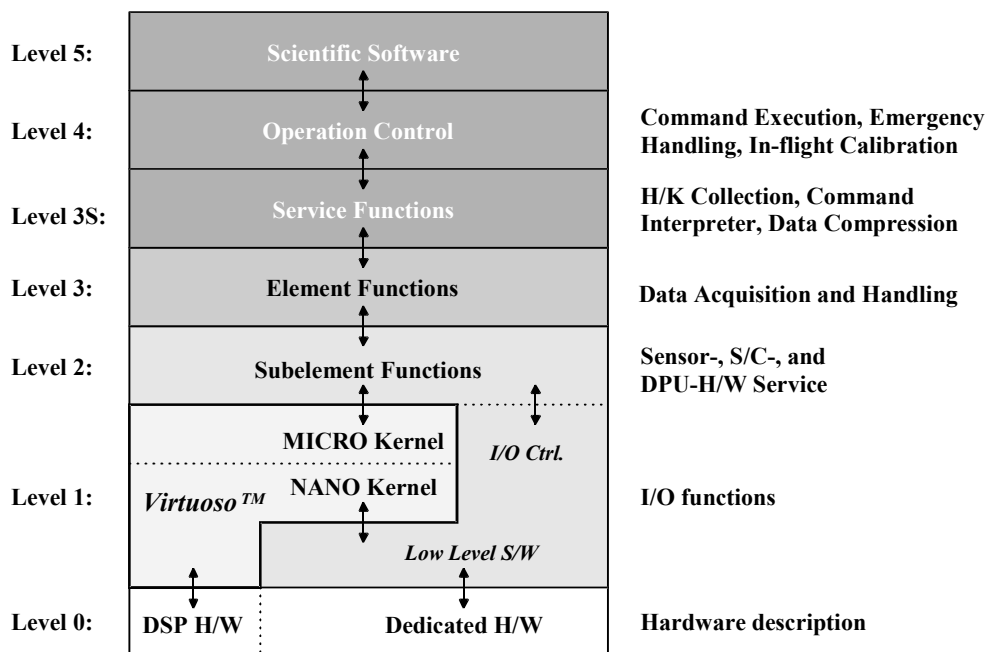

Fig. 2.8.1.1-1: DPU Software Levels

- Level 5: Scientific Software.



This level defines algorithms for automatic measurement by using the operation modes of each of the three experiments, e.g. search for organics, deuterium search.

- **Level 4: Operation Control.**
Level 4 provides procedures for each operation mode of the three ROSINA units (DFMS, RTOF, COPS). These procedures implement the operation modes as defined by the scientists. Procedures for In-flight calibration and housekeeping monitoring of the sensors are included
- **Level 3S: Service Functions.**
The Service Functions level is one of two level 3 sublevels and it implements functions providing software services, e.g housekeeping collection, command interpreter, data compression.
- **Level 3: Element Functions.**
This level contains basic data acquisition and handling procedures. Data acquisition operates all three units DFMS, RTOF, and COPS in parallel. Data formatting processes both, H/K and science data, for the S/C telemetry interface.
- **Level 2: Sub-element Functions.**
Level 2 interfaces to both the RTOS and the low level driver software. It consists of service functions to the serial devices of DFMS, RTOF, and COPS. On the spacecraft side, telemetry and telecommand interfaces served.
All software interfaces above this level are hardware independent.
- **Level 1: Low Level S/W.**
This level interfaces the H/W of the DPU with the next higher S/W level. Level 1 is shared by the RTOS Virtuoso and driver software. The RTOS interacts with processor devices. The drivers serve dedicated hardware. The boot loader program can load program data from the internal EEPROM or from the spacecraft via the telecommand interface.
- **Level 0: Hardware.**
Level 0 consists of hardware descriptions, like address, port, and data definitions.



The conceptual S/W architecture in Fig. 2.8.1.1-2 shows the basic S/W tasks of all levels (level number in brackets) and its dependencies followed by a short description of each basic task.

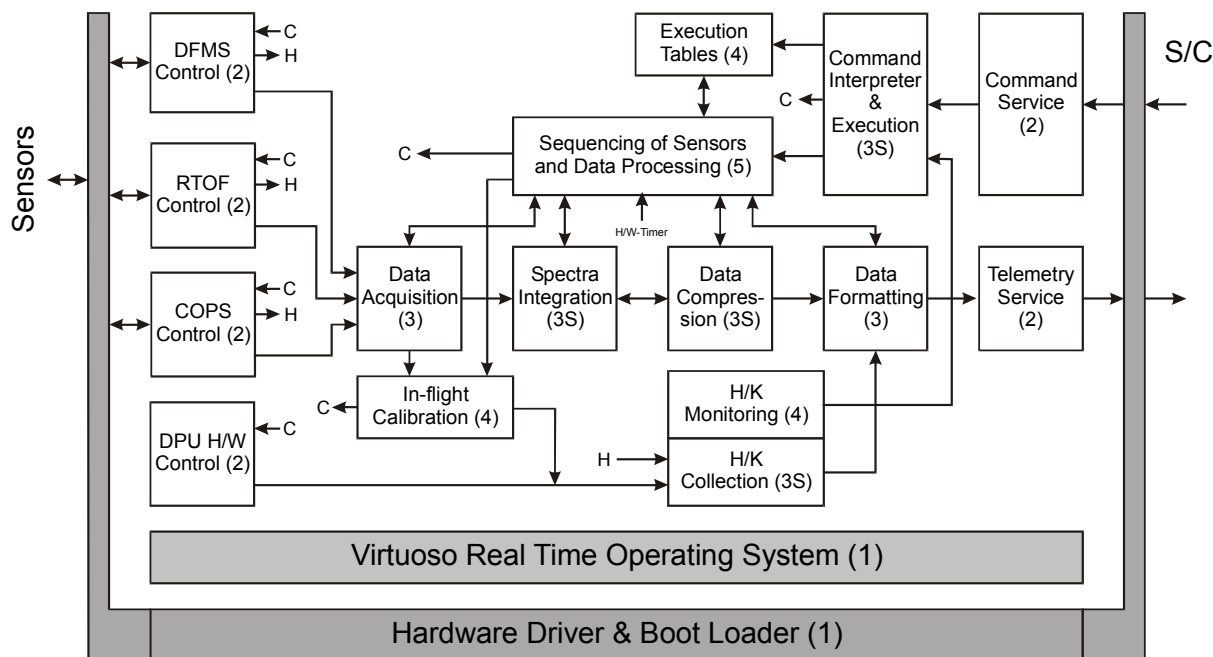

Fig. 2.8.1.1-2: Conceptual S/W Architecture

- Command Service: Decoding and error handling of commands from the S/C.
- Command interpreter & execution: Interpretation and execution (C) of low-level commands or interpretation and transfer to higher level tasks of high-level commands.
- Sequencing of sensors and data processing: Commands will be analysed for priority and queued into dedicated command execution chains. Autonomous sequencing of different measurement cycles, in cooperation with data acquisition. Execution of the commands (C) will be possible immediately or related to the measurement cycle.
- DFMS control: Commands for the sensor electronics section of DFMS will be forwarded and the execution will be checked.
- RTOF control: Same as "DFMS control".
- COPS control: Same as "DFMS control".

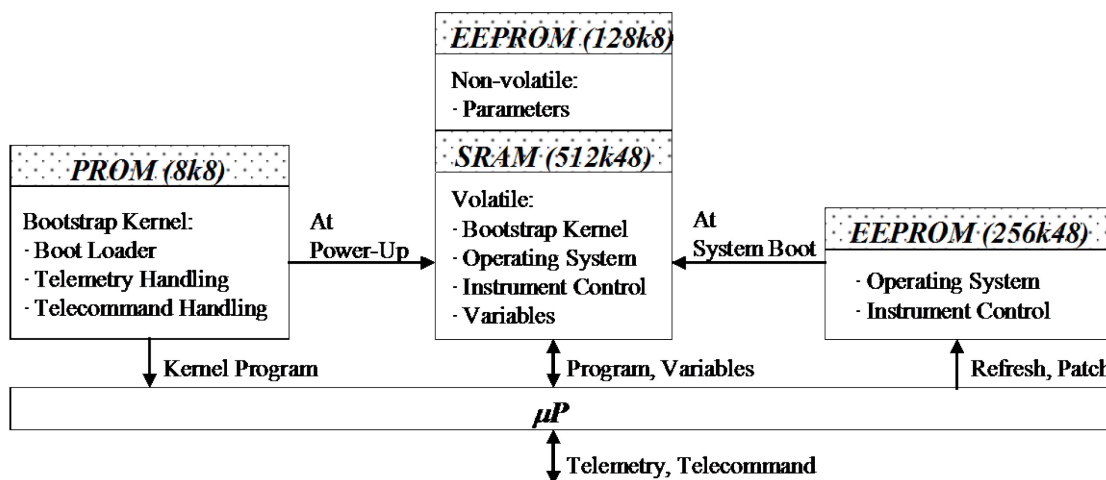

Fig. 2.8.1.1-3: Memory Configuration

2.3.1.2 Autonomy Concept

Due to the long signal turn-around times of ROSETTA and the non-availability of a downlink in certain circumstances, ROSINA will be capable of autonomous operations in various circumstances. One example is the asteroid flyby, where we are aware that it might be possible to have no up- or downlink available.

The concept of autonomous experiment monitoring consists of three steps as shown in figure 2.8.1.2-1:

- Subsystem individual control: Commands for the electronics of the subsystem will be forwarded and the execution will be checked.
- H/K collection and monitoring: Monitors the housekeeping information of the subsystems on a regular basis. Takes pre-programmed automatic reactions to avoid potential sensor damage.
- Command/Telemetry: Global long-term monitoring and failure reactions as ground operations.

A list of all HK which are monitored by the DPU, of their ranges and of the actions taken if these ranges are exceeded is given in annex D4 (HK-monitoring).

The measurement sequences of ROSINA are very flexible and can be adapted to the various mission phases, to the available bit rate and power and to very different scientific goals. Both mass spectrometers have a large number of possible modes, which however differ very little in the power consumption. A measurement sequence consists of different modes in sequence (background, inflight calibration, optimisation, scientific measurements), which will be commanded by the DPU in a preset way. As especially the optimisation routine can vary in time (function of temperature gradient, etc) the time when mode



changes occur cannot be precisely predicted. A measurement sequence can last from a few minutes up to ~days and can be repeated indefinitely. For a detailed explanation of instrument modes see annexes D1-D3.

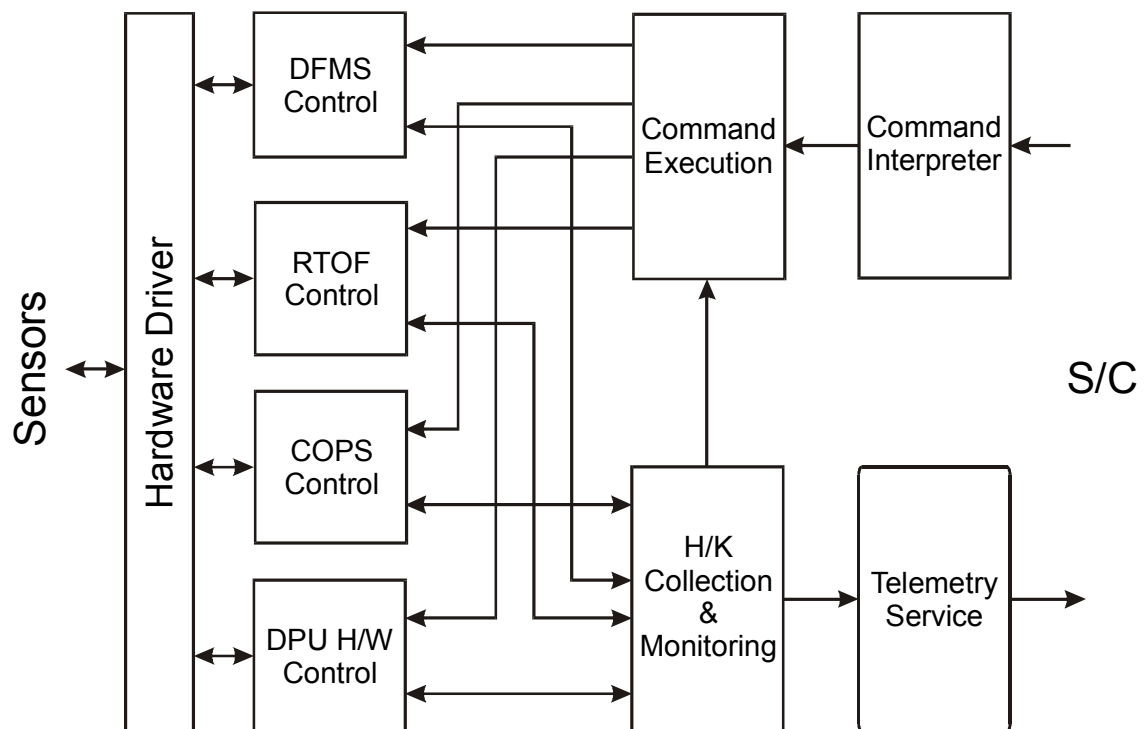

Fig. 2.8.1.2-1: Experiment Monitoring

2.3.1.3 Software Maintenance Approach

It will be possible to load particular memory areas from ground via telecommand packets, as described in EID-A chapter 2.8.3. It will be possible to dump any memory area to ground via telemetry packets, as described in EID-A chapter 2.8.3.



2.3.1.4 DPU – S/C Memory Management Services

2.3.1.4.1 1. Memory Types and IDs

ID	Word Width (bits)	Address Range	Description
120	48	0x00000000 .. 0x0005FFFF	Program Memory
121	48	0x00060000 .. 0x0007FFFF	Sensor Function Memory
122	48	0x00C00000 .. 0x00C1FFFF	EEPROM 1
123	48	0x00C20000 .. 0x00C3FFFF	EEPROM 2
124	32	0x00000000 .. 0x000DFFFF	Data 1 Memory
125	32	0x00400000 .. 0x004FFFFFFF	Data 2 Memory
126	32	0x000E0000 .. 0x000FFFFFFF	Table Memory
127	32	0x00000000 .. 0x0007FFFF	Start Address

2.3.1.4.2 2. Allowed Memory Types and Addresses for Bench and SIS Tests

ID	Word Width (bits)	Address Range	Description
120	48	-	Not allowed
121	48	0x0007D000 .. 0x0007EFFF	Program Memory test
122	48	0x00C00000 .. 0x00C1FFFF	Only for S/W Update
123	48	0x00C20000 .. 0x00C3FFFF	Only for S/W Update
124	32	-	Not allowed
125	32	0x004FE000 .. 0x004FFFFFFF	Data 2 Memory test
126	32	0x000FE000 .. 0x000FFFFFFF	Data 1 Memory test
127	32	-	Not allowed



2.4 Budgets

2.4.1 Mass and Power

Below are typical power numbers for the operation of ROSINA. For a detailed power budget for the different scientific modes, see 4.2

	Mass	Mean Power	Max. Power*
DFMS	16.2 kg	19 W	28 W
RTOF	14.7 kg	24 W	27 W
COPS	1.6 kg	3 W	7 W
DPU	2.3 kg	3 W	7 W
Total	34.8 kg	49 W	N/A

* it is not foreseen to operate DFMS, RTOF and COPS in their maximum power modes simultaneously

2.4.2 Data Rates / DMS Resource Requirements

2.4.2.1 SSMM Utilisation

The tables below summarise the requirements for the expected use of the on-board mass memory by ROSINA for the different mission phases

SSMM Utilisation		Mission Phase: Commissioning		Instrument: ROSINA
Data Type	Description	Volume MByte	Operational Usage	
Non-Science Telemetry	Housekeeping	2	= 25 bit/s	
Science Telemetry		4	= 50 bit/s	
Context		1 kByte		
S/W patches		0.5		
Other				

SSMM Utilisation		Mission Phase: Asteroid Fly-by 1		Instrument: ROSINA
Data Type	Description	Volume MByte	Operational Usage	
Non-Science Telemetry	Housekeeping	2	= 25 bit/s	



Rosetta ROSINA

Reference : **RO-ROS-Man-1009**
 Issue : **3** Rev. : **0**
 Date : 26.04.19
 Section : 2 Page : **88**

Science Telemetry		4	= 50 bit/s
Context		1 kByte	
S/W patches		0.5	
Other		TBD	

SSMM Utilisation		Mission Phase: Asteroid Fly-by 2		Instrument: ROSINA	
Data Type	Description	Volume MByte	Operational Usage		
Non-Science Telemetry	Housekeeping	2	= 25 bit/s		
Science Telemetry		8	= 100 bit/s		
Context		1 kByte			
S/W patches		0.5	Only for contingency upload of SW		
Other		TBD			

SSMM Utilisation		Mission Phase: Comet approach		Instrument: ROSINA	
Data Type	Description	Volume MByte	Operational Usage		
Non-Science Telemetry	Housekeeping	2	= 25 bit/s		
Science Telemetry		100	= 1300 bit/s		
Context		1 kByte			
S/W patches		0.5			
Other					

SSMM Utilisation		Mission Phase: Nucleus mapp.		Instrument: ROSINA	
Data Type	Description	Volume MByte	Operational Usage		
Non-Science Telemetry	Housekeeping	2	= 25 bit/s		
Science Telemetry		100	= 1300 bit/s		
Context		1 kByte			
S/W patches		0.5			
Other		TBD			



Rosetta ROSINA

Reference : **RO-ROS-Man-1009**
Issue : **3** Rev. : **0**
Date : 26.04.19
Section : 2 Page : **89**

SSMM Utilisation	Mission Phase: Comet escort		Instrument: ROSINA
Data Type	Description	Volume MByte	Operational Usage
Non-Science Telemetry	Housekeeping	2	= 25 bit/s
Science Telemetry		200	= 2600 bit/s
Context		1 kByte	
S/W patches		0.5	
Other			



2.4.3 Thermal Budget

2.4.3.1 Heater Power Requirements

Experiment Unit	Power [W]
DFMS Sensor	3
RTOF Sensor	0
COPS Sensor	0
DPU	0

Table 2.4.3-1: Heater Power Requirements

The non-ops heaters are switched on automatically by the S/C if the temperature drops below the specified lower non-ops value at the temperature reference point (see 2.2.5).

2.4.3.2 Heat Exchange Budget

The heat exchange, given as a range is shown in Table 2.4.3-1

Experiment Unit	Operating [W]	
	Cond.	Rad.
DFMS Sensor	3.8	
Electronics	15.1	
RTOF Sensor	3.2	
Electronics	19.0	
COPS	2.1 / 7.0 *	
DPU	3	

* about 3 W dissipated in gauge filaments, and coupled to space

Table 2.4.3-2: Heat Exchange



2.4.3.3 Temperature Monitoring

2.4.3.3.1 S/C Provided Thermistors

Experiment Unit	S/C powered thermistors	Temperature Range	Location
DFMS Sensor	1 + 1	-55 to 90 °C	Electronics housing / Detector
RTOF Sensor	1 + 1	-55 to 90 °C	Sensor head
COPS Sensor	1 + 0	-55 to 90 °C	Electronics
DPU	0	N/A	N/A

Table 2.3.3-5: Temperature Sensors

2.4.3.3.2 Experiment Provided Temperature Sensors

Experiment Unit	Experiment provided Temperature Sensors	Temperature Range	Location
DFMS Sensor	1	-55 to 150 °C	DFMS Magnet
	1	-55 to 150 °C	DFMS Detector
	1	-80 to 500 °C	Ion Source Heater
RTOF Sensor	2	-55 to 150 °C	RTOF Detectors
	2	-80 to 500 °C	Ion Source Heaters
	1	N/A	ETS Board
	1	N/A	ETS_L Board
	1	N/A	Gas pulser
	1	N/A	Ion pulser
COPS Sensor	1	-55 to 150 °C	Gauge G1
	1	-55 to 150 °C	Electronics Board 2
DPU	0	N/A	N/A

Table 2.3.3-6: Experiment Provided Temperature Sensors



3 Experiment Operations

3.1 ROSINA FM Operations Manual

3.1.1 Operating principles

ROSINA consists of three sensors and a common DPU. All sensors are operated independently from the others. The DPU controls all the housekeeping values and issues commands to the sensors autonomously or by TC. It collects the science data, does on board data evaluation and compression and sends the HK and the science data to the S/C.

The software is divided into several levels. In the top level predefined sequences can be commanded by TC. They are based on predefined instrument modes, which are executed in sequence in order to achieve a given scientific goal. The modes themselves consist of predefined parameter settings and sub functions.

There are a few restrictions to the operation of ROSINA:

COPS has to be monitoring the ambient pressure whenever RTOF or DFMS are turned on.

The pressure has to be below 10^{-6} mbar in order to operate RTOF or DFMS. COPS will switch automatically off whenever the pressure rises above 10^{-5} mbar. On ground RTOF and DFMS can only be operated whenever a vacuum pump is connected to the sensor and the pressure is below 10^{-6} . COPS can only be operated in a vacuum chamber with a pressure below 10^{-6} mbar.



3.1.2 General

The ROSINA FM instrument is a delicate instrument requiring great precautions with respect to handling, cleanliness, and operation. Whereas the DPU is a normal electronics box containing neither high voltages nor pyros and can therefore be handled by standard rules, all three sensors have to be handled with exceptional care. DFMS and RTOF are built to ultrahigh vacuum standards and are closed off by a cover. However they need to be pumped app. every two weeks to maintain a vacuum below 10^{-6} mbar. COPS needs permanent purging with nitrogen.

The two mass spectrometers use high voltages up to 9 kV. Dust or humidity on the isolating ceramic parts may cause permanent damage to the sensors.

All three sensors contain delicate structures which can easily be broken off like for example the grids of the COPS nude gauge or the attraction grids of RTOF and DFMS. The isolating ceramic parts of DFMS and RTOF are vulnerable to any mechanical force. This is especially true for the reflectron of RTOF (can be broken off), the feedthroughs (possible leaking) and the isolating ceramic rings close to the covers.

Due to the fact that the pressure inside the sensors is not known except during active pumping, no voltages should be applied to the inner parts of the sensors during normal system tests. The HV safety plugs have to be connected at all times. Additionally to the high voltages there are a number of other activities which cannot be performed on ground or only during active pumping of the sensors (see chapter 2).

The filaments and microtips of COPS will suffer permanent damage if turned on in ambient pressure. That means that very great care has to be taken not to switch on any voltages affecting the gauges of COPS. Only the 28V can be switched on during S/C tests in ambient pressure.

3.1.3 Safety aspects / HV

For the safety aspects regarding high voltage, pyrotechnics and pressurized items consult the safety and hazard analysis document (ROS-DOC-4001).

For the on ground operation of ROSINA the following activities may cause



permanent damage to the sensors:

- Cover operation
- Voltages applied to the ion optical parts inside the two mass spectrometers
- Operation of the gas calibration unit
- Operation of the heaters inside the vacuum part of the sensors
- Operation of the filaments
- Operation of the microtips

Therefore the following guidelines have to be followed at all times:

1. HV plugs have to be installed at all times except during SPT's where DFMS and RTOF are actively pumped and the pressure inside the sensors is known to be less than 10^{-7} mbar.
2. HV plugs have to remain installed during system tests (including TV tests)
3. All commands related to the covers must not be activated. This is especially true for the pyro commands but also for all other commands (cover open, close, etc.)
4. All commands related to filaments must not be activated (DFMS, RTOF) except during SPT's (see point 1)
5. All commands related to filaments or microtips for COPS must not be activated except in a vacuum below 10^{-6} mbar.
6. No voltages for the COPS ram gauge may be set except in a vacuum below 10^{-6} mbar.
7. Ion source heaters must not be activated during ground operation except during SPT's (see point 1).
8. RDP heater (DFMS) should not be activated except during SPT's (see point 1).
9. All commands related to the gas calibration units (RTOF and DFMS) must not be activated except during SPT's.

3.1.4 Cleanliness / Purging / Pumping

Extreme care has to be taken with the cleanliness. Both mass spectrometers have high voltage isolation parts made out of ceramics. Dust or high humidity could lead to HV discharges thus damaging the sensor permanently.

COPS has to be purged permanently according to the purging procedure RO-ROS-MAN-1001. In case this purging has to be disrupted (shipping of S/C, etc.) Cops should not be turned on before the purging has been resumed for at least 24 h.



3.2 Operations Plan

3.2.1 Ground Test Plan

deleted (March06)

3.2.2 Commissioning Phase near Earth (LEO)

The covers of RTOF and DFMS should only be opened after the spacecraft has had sufficient time to outgas. Also the main orbit and attitude correction maneuvers of the spacecraft which use a lot of thruster firing should be finished by the time the covers are opened for the first time (appr. 70 days after launch). Before cover opening the ambient pressure as recorded by COPS MICROTIPS OR FILAMENT has to be below 10^{-6} mbar. After cover opening enough time has to elapse (~days) to allow an outgassing of the sensors before power is turned on. To accelerate outgassing of the DFMS ion source the ion source heater will be used. All three sensors should be checked out separately. For this operation near real-time commanding and science data are needed. Deatails are given in the flight operations procedure (annex B).

3.2.3 Instrument check-out and inflight calibration

A detailed check out of the entire instrument will be made during the initial turn on in the cometary neighborhood similar to the first commissioning. An inflight calibration program will be activated every 1-2 weeks. Both mass spectrometers are equipped with gas tanks containing a gas mixture (He, CO₂ and Kr for RTOF, Ne, CO₂ and Xe for DFMS). A defined pressure inside the ion sources is built up with a regulated gas valve. The instrument response is then measured. The program will encompass internal calibration of the different ion detectors of the DFMS and RTOF and ion source and analysis operation modes as well as an absolute calibration of the overall sensitivity using the calibrated gas release system. This mode will run automatically from the DPU upon command from ground or upon internal command sequence stored in the DPU.



3.2.4 Flight Operations plans Mission Phase

Following are the special requirements for the different mission phases:

3.2.4.1 Cruise Phase / hibernation

No checkout / maintenance operation is needed for ROSINA during cruise phases / hibernation. Before going into hibernation the covers of RTOF and DFMS should be open.

3.2.4.2 Check-out

No passive checkout is foreseen. During active checkout the cover mechanisms have to be exercised and the background of the S/C will be monitored.

3.2.4.3 Planet fly-by's

ROSINA should be turned on during the Mars flyby to measure the martian exosphere. The measurement modes will be similar to the asteroid flyby's if feasible the planet fly-by's should be used to heat up the spacecraft experiment platform (turn it towards the sun) to outgas is so as not to let the dirt get sticky. No operation is planned for the earth fly-by's.

3.2.4.4 Asteroid Fly-By's

A few days (>5, TBC) prior to the asteroid fly-by's the COPS MICROTIPS OR FILAMENT, the RTOF and the DFMS have to be commissioned. The filaments of all three sensors need a slow and careful conditioning before the actual fly-by (based on the same procedures as the initial switch-on) and the instrument has to perform a thorough measurement of the background (outgassing of the spacecraft). The data rate however can be small during this period. During the actual fly-by the RTOF should be fully operating at the highest possible data rate to gather mass spectra with high spatial resolution. If power and available bit rate permit the DFMS will be used to complement RTOF by looking at specific molecules in a low mass resolution mode.

The sensors will be operated throughout the asteroid flyby's in the same measurement modes (gas channel RTOF, low resolution DFMS). That means no commanding will be necessary.

3.2.4.5 Comet Approach

After reaching the neighborhood of the comet, it is mandatory that the instrument is switched on as soon as possible to study outgassing and



cometary activity at large heliocentric distances. At these distances the expected cometary gas densities are low and S/C outgassing and instrument background must be reduced to the lowest possible level. This requires exposure of the experiment platform to sunlight for several days to accelerate degassing of adsorbed gases. This degassing process should be monitored by COPS MICROTIPS OR FILAMENT. The covers of the two sensors should be opened when S/C outgassing has been sufficiently reduced as determined by the COPS MICROTIPS OR FILAMENT. RTOF has a power savings mode where only the channel which is adapted to low densities will be operated which should allow an early turn on. Where this switch-on occurs will be determined by available spacecraft power and telemetry. DFMS and COPS should be turned on as soon as feasible from the power point of view. During commissioning the DFMS and RTOF ion sources will be degassed by the ion source heaters for several days. Careful conditioning of the filaments and use of the inflight calibration system have to be included in the commissioning phases. Regarding telemetry, cometary gas densities will be low at large heliocentric distances, requiring very long integration periods and monitoring of spacecraft outgassing. Thus, telemetry requirements may be significantly lower than later when the gas densities are larger.

3.2.4.6 Mapping Phase

During the mapping phase of the mission, the instrument will be used to survey the nucleus surface. To search for active areas on the nucleus surface, where volatiles are at or near the surface and to search for suitable landing places for the SSP, a survey of the gas density around the nucleus at an altitude of about one nuclear radius is required. The intensive study of the gas density, composition and dynamics must be continued during the entire mapping and close survey phase to achieve the science goals. It will also require use of the narrow FOV of the DFMS which must be directed towards the nucleus.

3.2.4.7 Escort to Perihelion

After the SSP has been deployed and during the escort to perihelion phase, the gas production rate will increase. The increased production will allow accurate measurements at large cometocentric distances. In this phase the RTOF will serve as survey instrument, measuring a very large mass range whereas the DFMS will concentrate on individual masses to get a full mass resolution for critical mass peaks (e.g. mass 28 amu). To study the release of gas from grains (extended sources), and to get insight into the complex coma chemistry and the interaction between gas and dust, several radial excursions from about one nuclear radius to at least 1000 km with extended stays at large



distances may be required. These excursions must be interspersed with detailed investigation of the sunward near nucleus hemisphere of the coma. The observations of the outgassing behavior of active areas during terminator crossings and in the shadow will be a diagnostic tool for the morphology of the nuclear surface regions in these areas. These observations require stays above the dawn and dusk terminator regions and occasional observations of the nightside of the coma. To measure minor constituents of the gas and to get isotope ratios for a large number of species it is essential to have very long integration periods. Depending on the actual gas flow field in the vicinity of the nucleus, it may also be necessary to operate the instrument for extended periods of time while it is not pointed at the nucleus. Angular scans using the narrow FOV of the DFMS will be required for studying individual gas sources on the nucleus.

3.2.5 Interferences

Operation of the ACS thrusters interferes with the operation of the instrument and could even cause permanent damage. It is therefore mandatory that the instrument is put in a safe mode before the thrusters are operated. The instrument can only be turned on again 10 minutes after the thrusters are turned off. Several hours may be necessary after instrument turn off to reach stable background conditions.

As an additional safety measure, the COPS MICROTIPS OR FILAMENT will be used as a monitor of ambient conditions and will signal the mass spectrometer to turn off if ambient pressure should increase above a preset limit (10^{-6} mbar), for instance due to a cometary outburst during the near comet phases of the mission or episodic S/C outgassing. If the pressure exceeds 10^{-4} mbar the COPS MICROTIPS OR FILAMENT will also be turned off.

3.2.6 Operational constraints

There are no pointing constraints, nor constraints to other instrument operations for ROSINA. RTOF in full mode (both channels active) should not be operated in parallel to DFMS for thermal reasons.

3.3 Failure detection and recovery strategy



Rosetta ROSINA

Reference : **RO-ROS-Man-1009**

Issue : **3** Rev. : **0**

Date : 26.04.19

Section : 3 Page : **100**

This section is maintained as a separate procedure (Annex C, RO-ROS-MAN-1023, ROSINA Contingency Recovery Procedure)



4 Mode Descriptions

4.1 Mode Transition Table

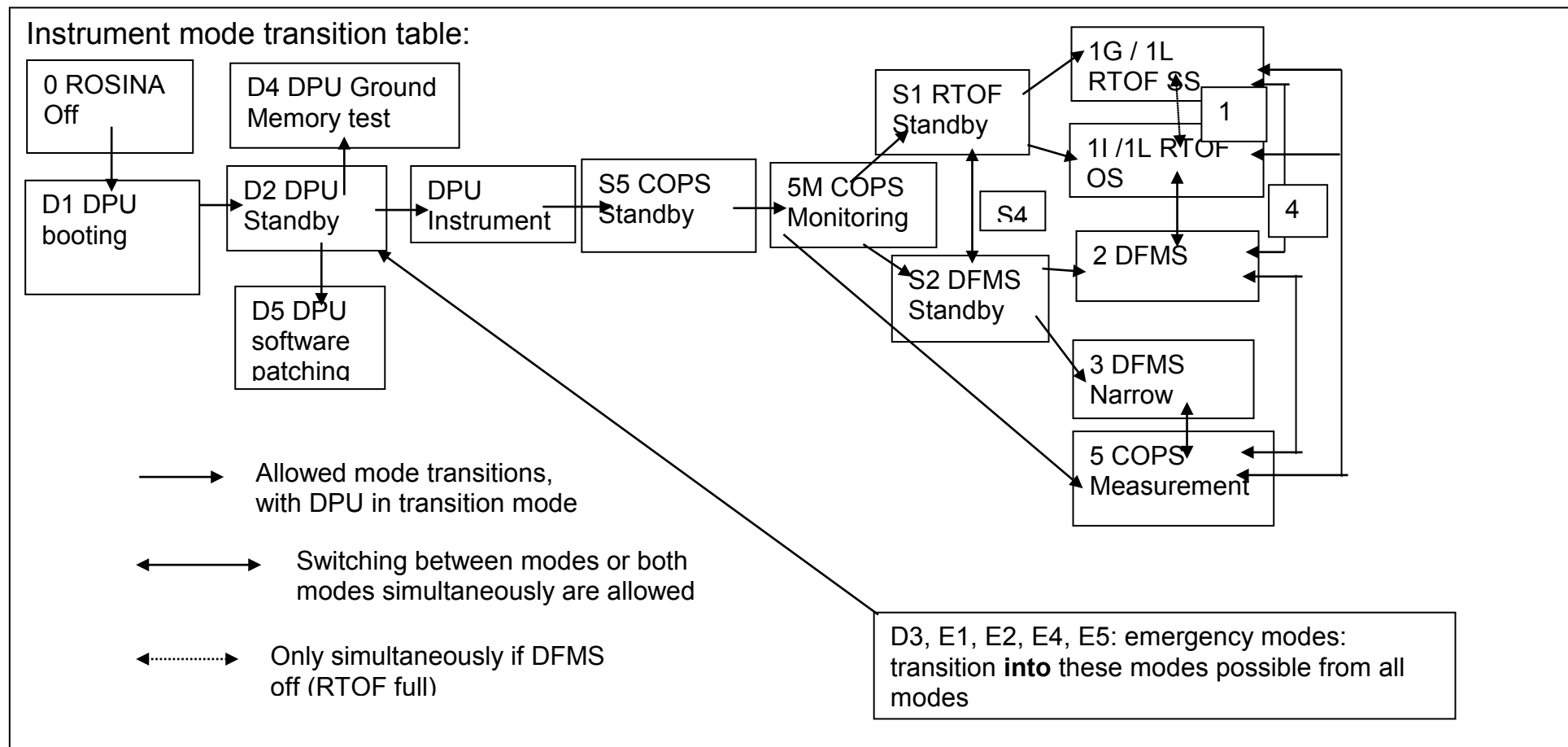



The detailed mode transition tables for DFMS and RTOF can be found in Annex D1, D2.

4.2 Detailed Mode Description

Each sensor operation is independent from the others, except that COPS is required to be on whenever DFMS and/or RTOF are switched on. Simultaneous operation of the full RTOF and DFMS is not foreseen (power). Transition into emergency modes possible from all respective instrument modes. Transitions during ground tests as during measurement modes. Each sensor has a large number of individual “submodes” which are described in the annexes D1-D3. The science operation consists of a sequence of individual submodes, e.g. Calibration mode followed by background mode, followed by gas mode followed by ion mode, etc. for DFMS and in parallel permanent gas mode in high sensitivity for RTOF. Such a sequence can last between a few minutes up to 24 h or more and can be repeated indefinitely.

4.2.1 Instrument modes

The allowed ROSINA instrument mode configurations are specified in the following table:

No.	Experiment Mode	DPU	DFMS	RTOF	COPS	Power (W)	Data Rate (bits/s)
0	Instrument off	Off	off	off	off	0	0
D1	DPU Booting	on	off	off	off	6	0
D2	DPU Standby	on	off	off	off	4.5	25
D3	DPU Emergency	on	off	off	off	4.5	500
D4	DPU Ground Test	on	off	off	off	6	500
D5	DPU S/W patch	on	off	off	off	6	500
S1	RTOF Standby	on	off	stby	Micro	20.5	25
E1	RTOF Emergency	on	off	on	Micro	20.5	500
G1	RTOF ground test	on	off	stby	off	25	30k



Rosetta ROSINA

Reference : **RO-ROS-Man-1007**

Issue : **3** Rev. : **0**

Date : 26.04.19

Section : 4 Page : **103**

1L	RTOF Low Power	on	off	on	Micro	29	1k
1G	RTOF Gas	on	off	on	Micro	32	1k
1I	RTOF ion	on	off	on	Micro	29	500
1	RTOF Full (Gas and Ion)	on	off	on	Micro	42	1.5k
S2	DFMS Standby	on	stby	off	Micro	25	25
E2	DFMS Emergency	on	on	off	Micro	25	500
G2	DFMS Ground Test	on	stby	off	off	25	18k
2	DFMS Normal	on	on	off	Micro	28	1k
3	DFMS Narrow	on	on	off	Full/nude	31	1k
S4	RTOF + DFMS Standby	on	stby	stby	Micro	36.5	25
E4	RTOF + DFMS Emergency	on	on	on	Micro	36.5	500
G4	RTOF +DFMS Ground test	on	stby	stby	stby	32.5	46k
4	RTOF Single + DFMS	on	on	on	Full	52	2k
S5	COPS Standby	on	off	off	stby	8	25
E5	COPS Emergency	on	off	off	on	8	500
G5	COPS Ground test	on	off	off	stby	8	500
5M	COPS monitoring	on	off	off	Nude/Micro	9	25
5	COPS Full	on	off	off	Full	11	25

Table 3.1 shows the major operation mode definitions for the instrument, the state of the different units, the average power consumption and the mode command parameter



4.2.2 DPU Modes:

DPU Modes:

Mode	Sub-mode	28V	Experiment	HV	Activated by	Typical time	Used in phase	Description/ Frequency of activation
DPU Booting	Initial booting	On	Off	Off	S/C	10s	Ground test	Ground test Mode
	DPU Patching	On	Off	Off	S/C	N/A	All phases	Software download
DPU Standby	Normal	On	Off	Off	S/C or DPU	N/A	All phases	All the Instruments are switched Off excepted the DPU
DPU Instrument	Pressure Monitoring	On	COPS On	-	DPU	10s	All phases	Monitoring of pressure and gas parameters
	Instruments Mode	On	COPS On/Off DFMS On/Off RTOF On/Off	Off / On	DPU	N/A	All phases	All the sensor modes
DPU Emergency	Pressure Alert	On	Off	Off	DPU	N/A	All phases	All the sensors are switched Off
	Emergency	On	TBD	TBD	DPU	N/A	All phases	Emergency handling for all the Instruments TBD
DPU Ground Test	DPU Memory Test	On	Off	Off	S/C	N/A	Ground test	Test sequence during ground test
	Instruments Test	On	Off / On	Off / On	DPU	N/A	Ground test	Test sequence during ground test
DPU Transition		On	On/Off	On / Off	DPU	N/A	All phases	Transitions of all the Instruments Mode



4.2.3 DFMS:

DFMS has several parameters in order to measure mass spectra of ions or neutrals between two given mass numbers, with a high or low mass resolution, with adjustable electron emission current and energy. It has three different detector systems with different detector modes in order to accommodate the different density regimes of the mission. The main unit operational modes are given below. Full control of all sensor modes is within the DPU. Data compression is achieved by integration over several spectra depending on data rate. A more complete list can be found in annex D1

Mode	Sub-mode	28V	HV	Filament	Cover	Ion source heater	GCU	Activated by	Typical time	Used in phase	Description / Frequency of activation
S2 Standby	Cover initial opening	Off	Off	Off	Pyro firing	Off	Off	S/C	N/A	Commissioning in LEO	Breaking of vacuum seal
	Safe mode	On	off	off	open	off	off	S/C or DPU	N/A	All phases	Standby during turn on /turn off sequences
	High Pressure mode	On	off	off	closed	off	off	S/C or DPU	N/A	All phases	Safe mode during thruster firing and high pressure alert
	Ion Source cleaning	On	off	off	open	on	off	DPU	1 h	All phases	Regular cleaning of ion source by heating, 1 /week (TBC)
2 Normal	Noise	On	On	On	open	off	off	DPU	10 s	All phases	Background measurement of detectors, every few minutes



Rosetta ROSINA

Reference : **RO-ROS-Man-1007**

Issue : **3** Rev. : **0**

Date : 26.04.19

Section : 4 Page : **106**

	Background	On	On	On	Partially open	off	off	DPU	5 min	All phases	Background measurement of sensor by blocking off cometary material, < 1/day
	High res.	On	On	On	open	off	off	DPU	10 s /mass	All phases	Normal high resolution mode, mass spectrum of one mass number per measurement
	Low res	On	On	On	open	off	off	DPU	10 s / 8 masses	All phases	Normal low resolution mode, mass spectrum of eight mass numbers per measurement
	Intercalibration	On	On	On	open	off	off	DPU	10 min	All phases	Intercalibration of all three detectors (LEDA, CEM, Faraday), 1 /day
	In-flight calibration	On	On	On	open	off	on	DPU	30 min	All phases	In-flight calibration with gas calibration unit, 1/week
3 Narrow angle	High res.	On	On	On	open	off	off	DPU	N/A	Special S/C mode	Normal high resolution mode, mass spectrum of one mass number per measurement
	Low res.	On	On	On	open	off	off	DPU	N/A	Special S/C mode	Normal low resolution mode, mass spectrum of eight mass numbers per measurement
G2 Ground	Normal	On	off	Off	closed	off	off	DPU	N/A	Ground test	Test sequence during ground test if no vacuum



test											pump is attached
	Special test	On	On	On	closed	off	off	DPU	2 h	Special ground test	Test sequence during ground test if vacuum pump is attached

Emergency modes TBD

4.2.3.1 Power Consumption:

The power consumption of DFMS is composed of five main components, namely of the standby power (low voltage converters and main controller), of the analyzer part, of the filament, of the ion source heater and of the cover motor. The power consumption of DFMS is more or less independent of the detector used. It does vary neither with low or high resolution nor with the zoom optics. The following table shows the five contributions:

	Power (W)
Standby mode (LVPS, MC)	16
Analyzer Part	1
Filament	2
Ion source heater*	10
Cover motor	2

- Not run in parallel to analyzer part, filament or cover motor

The power used in each mode can therefore be calculated. A normal measurement mode (including noise mode or calibration



Rosetta ROSINA

Reference : **RO-ROS-Man-1007**

Issue : **3** Rev. : **0**

Date : 26.04.19

Section : 4 Page : **108**

mode) needs 19 W; a background mode with cover 21 W, the ion source heater needs 26 W.



4.2.4 RTOF:

RTOF has several parameters in order to measure mass spectra of ions or neutrals between two given mass numbers, with a high or low mass resolution, with adjustable electron emission current and energy. It has two channels, one optimized for neutrals (Storage Source SS), one optimized for ions (Ortho Source (OS)) with two different data acquisition system. Both channels, however, can also be used vice-versa. The main operational modes are given below. Full control of all sensor modes is within the DPU. Data compression is achieved by integration over several spectra and 2D wavelet compression depending on data rate. A more complete list can be found in annex D2

Mode	Sub-mode	28 V	HV	Filament Gas	ETS /ETS_L	Cover	Ion source heater	GC U	Activated by	Typical time	Used in phase	Description / Frequency of activation
S1 Standby	Cover initial opening	Off	Off	Off	Both off	Pyro firing	Off	Off	S/C	N/A	Commissioning in LEO	Breaking of vacuum seal
	Safe mode	On	off	off	Both off	open	off	off	S/C or DPU	N/A	All phases	Standby during turn on /turn off sequences
	High Pressure mode	On	off	off	Both off	closed	off	off	S/C or DPU	N/A	All phases	Safe mode during thruster firing and high pressure alerts
	Ion Source cleaning	On	off	off	Both off	open	on	off	DPU	>1 h	All phases	Regular cleaning of ion source by heating, 1 /week (TBC)
1L Low Power	Noise	On	On	On	ETS	open	off	off	DPU	10 s	All phases	Background measurement of detectors, every few minutes



Rosetta ROSINA

Reference : **RO-ROS-Man-1007**
 Issue : **3** Rev. : **0**
 Date : 26.04.19
 Section : 4 Page : **110**

	Background	On	On	On	ETS	Partially open	off	off	DPU	5 min	All phases	Background measurement of sensor by blocking off cometary material, < 1/day
	Measurement	On	On	On	ETS	open	off	off	DPU	100s /mass spectrum	All phases	Normal mass spectrum mass 1-500 amu/e
	In-flight calibration	On	On	On	ETS	open	off	on	DPU	30 min	All phases	In-flight calibration with gas calibration unit, 1/week
1G Gas	Noise	On	On	On	ETS	open	off	off	DPU	N/A	All phases	Background measurement of detectors, every few minutes
	Background	On	On	On	ETS	Partially open	off	off	DPU	5 min	All phases	Background measurement of sensor by blocking off cometary material, < 1/day
	Measurement	On	On	On	ETS	open	off	off	DPU	100s /mass spectrum	All phases	Normal mass spectrum mass 1-500 amu/e
	In-flight calibration	On	On	On	ETS	open	off	on	DPU	30 min	All phases	In-flight calibration with gas calibration unit, 1/week
1I Ion	Noise	On	On	Off	ETS_L	open	off	off	DPU	N/A	All phases	Background measurement of detectors, every few minutes
	Background	On	On	Off	ETS_L	Partially open	off	off	DPU	5 min	All phase	Background measurement of sensor by blocking off



Rosetta ROSINA

Reference : **RO-ROS-Man-1007**
 Issue : **3** Rev. : **0**
 Date : 26.04.19
 Section : 4 Page : **111**

											s	cometary material, < 1/day
	Measurement	On	On	Off	ETS_L	open	off	off	DPU	100s /mass spectrum	All phases	Normal mass spectrum, ions, mass 1-500 amu/e
1 RTOF full	Noise	On	On	on	ETS and ETS_L	open	off	off	DPU	N/A	All phases	Background measurement of detectors, every few minutes
	Background	On	On	on	ETS and ETS_L	Partially open	off	off	DPU	5 min	All phases	Background measurement of sensor by blocking off cometary material, < 1/day
	Measurement	On	On	on	ETS and ETS_L	open	off	off	DPU	100s /mass spectrum	All phases	Normal mass spectrum, ions and gas, mass 1-500 amu/e
G1 Ground test	Normal	On	off	Off	ETS and ETS_L	closed	off	off	DPU	N/A	Ground test	Test sequence during ground test if no vacuum pump is attached
	Special test	On	On	On	ETS and ETS_L	closed	off	off	DPU	2 h	Special ground test	Test sequence during ground test if vacuum pump is attached

Emergency modes TBD



4.2.5 COPS Operational modes:

COPS has two principal modes: one is the monitoring mode, the other one the scientific mode. In the monitoring mode the nude gauge is used alone in the science mode both gauges are used. For redundancy reasons it is also possible to do the monitoring mode with the ram gauge in case of a nude gauge failure. Full control of all sensor modes is within the DPU. A more complete list can be found in annex D3

Mode	Sub-mode	28V	Filament	Microtips	Activated by	Typical time	Used in phase	Description / Frequence of activation
G5 Standby	Safe mode	On	Off	off	DPU	N/A	All phases	
5M Microtips	Monitoring low power	On	off	on	DPU	10 s	All phases	Monitoring of pressure
5 Filament	Monitoring	On	On	off	DPU	10 s	All phases	Monitoring of pressure
5 Full	Measurement	On	On	on	DPU	10 s	All phases	Measurement of gas parameters T,v,p

4.2.5.1 Power Consumption:

The power consumption of COPS is composed of two main components, namely of the standby power (low voltage converters and main controller), and of the filament. The power used by the microtips can be neglected. The following table shows the two contributions:



Rosetta ROSINA

Reference : **RO-ROS-Man-1007**
Issue : **3** Rev. : **0**
Date : 26.04.19
Section : 4 Page : **114**

	Power (W)
Standby mode (LVPS, MC)	4.5
Filament	2

- Not run in parallel to analyzer part, filament or cover motor

The power used in each mode can therefore be calculated. A normal measurement mode with microtips needs 4.5 W; with the filament 6.5 W.



5 Operational procedures

5.1 On-board control procedures

5.1.1 On-Board Control Procedures

The table below gives an overview of the use of on-board control procedures (OBCPs,).

ON-BOARD CONTROL PROCEDURES SUMMARY, Instrument: ROSINA	
OBCP Name	Function
PL_OBCP_5_RN.1	Switch-On
PL_OBCP_5_RN.2	Switch-Off
PL_OBCP_5_RN.3	Emergency S/W reload

5.1.2 On-Board Monitoring Requirements

The table below gives an overview of the use of on-board monitoring. No parameters have to be monitored because the DPU monitors all HK's.

DMS MONITORING		Instrument: ROSINA
Monitored Entity	Monitoring Requirements	Action on Error
Parameters		
Events		
Operation mode change report	Wait for ROSINA ready to switch-off	Switch-Off
...		
Event 8	TBD	



5.1.3 Information Distribution Requirements

The tables below give an overview of the information required and offered by the instrument .

INFORMATION REQUIRED		Instrument: ROSINA
Entity	Requirements	Remarks
Parameters		
Giada Dust Flux	every 1 min	2 Octets , 0xEE if not available
Events		
Event 1		
...		
Event 8		

INFORMATION OFFERED		Instrument: ROSINA
Entity	Availability	Remarks
Parameters		
COPS Pressure	Every HK Frame (SID 32, nom. once a minute)	1 Octet Pressure 1 Octet Gradient 0xFF if not available
Events		
COPS Pressure Alert	Event Packet (EID 44300)	1 Octet Pressure 1 Octet Gradient



5.2 Flight Control procedures

This document is maintained as a self standing document : Annex B,
RO-ROS-MAN-1015



6 Data Operations Handbook

6.1 Telecommand Function Definitions

See Annex F1

6.2 Telemetry Packet Definitions

6.2.1 DPU – S/C HousekeepingPackets

See Annex F2

6.2.2 Science Data Sets

Each Science Data Set consists of one or several Science Packets defined in 3.
 All values are in TM-words (16 bits).

6.2.2.1 DFMS

Type No.	Type Ident.	Name	Length	Packet Count	Usage	Description
D1	0x81	MCP Dual Raw	2062	2	Test + Calibration	8 HK + 2050 LEDA (A+B)
D3	0x83	MCP Raw	1034	1	Low / High Zoom	8 HK + 1024 LEDA
D5	0x85	MCP Full Raw Low	20662	11	Full spectrum low	20 * (8 + 1024)
D6	0x86	MCP Full Raw High	103302	51	Full spectrum high	100 * (8 + 1024)
D7	0x87	MCP 12bit	394	1	12bit data compr.	8 HK + 384 LEDA
D8	0x88	MCP 12bit Low/High	106	1	4 comb. pixel 12bit or center 128pix. 12bit	8 HK + 96 LEDA
D20	0x20	MCP Compressed	Max. 26426	Max. 13	Full or single	X * (8 HK + Y LEDA) (depends on compr. factor)
D40	0x40	CEM Full Raw High	Max. 32834	Max. 17	Full or single spectrum	X * (8 HK + 4 * Y CEM)
D42	0x42	FAR Full Raw High	Max. 8810	Max. 5	Full or single spectrum	X * (8 HK + 2 * Y FAR)



6.2.2.2 RTOF

Type No.	Type Ident.	Name	Length	Packet Count	Usage	Description
R20	0x14	ETS Full Raw	Max. 393740	Max. 193	Test + Calibration	123 HK + (X + 5) * 3 ETS
R21	0x15	ETSL Full Raw	Max. 393740	Max. 193	Test + Calibration	123 HK + (X + 5) * 3 ETSL
R22	0x16	ETS Select Raw	16354	8	300 mass * 18 points	123 HK + 16215 ETS
R23	0x17	ETSL Select Raw	16354	8	300 mass * 18 points	123 HK + 16215 ETSL
R24	0x18	ETS Compressed	Max. 98304	Max. 48	Full spectrum	123 HK + X ETS (depends on compr. factor)
R25	0x19	ETSL Compressed	Max. 98304	Max. 48	Full spectrum	123 HK + X ETSL (depends on compr. factor)
R26	0x1A	ETS HIRM	Max. 295340	Max. 145	Test + Calibration	123 HK + (3/4 X + 5) * 3 ETS

6.2.2.3 COPS

Type No.	Type Ident.	Name	Length	Packet Count	Usage	Description
C1	0x10	Full Pressure	72	1	Background + Alert	10 HK + 30 * 2 Pres.(60s)

6.2.3 Science Packet Definitions

6.2.3.1 DFMS Science Packet

Position	Bytes	Bits	Name	Data
000	1		DFMS Science Header	0x84
001	1		Type Identifier	
002	2		Packet Count	
004	2.. 4092		HK + Science Data	DFMS Science HK data only in first packet

6.2.3.2 RTOF Science Packet

Position	Bytes	Bits	Name	Data
----------	-------	------	------	------



000	1		RTOF Science Header	0x88
001	1		Type Identifier	
002	2		Packet Count	
004	2.. 4092		HK + Science Data	RTOF Science HK data only in first packet

6.2.3.3 COPS Science Packet

Position	Bytes	Bits	Name	Data
000	1		COPS Science Header	0x8C
001	1		Type Identifier	
002	2		Packet Count	
004	2.. 4092		Science Data	

6.2.4 Science Housekeeping Definitions

A set of science related HK data is transmitted (in addition to normal housekeeping data) at the beginning of each Science Data Set. A description of these data can be found in the general HK description document (annex D4).

6.2.4.1 DFMS Science HK Data, Length 8 words

Position	Bytes	Bits	Name	Data
000	1		DFMS Science HK Header	0xC4
001	1		Spare	
002	2		Voltage flags 1	
		15..14	MG	0 = Off, 1 = Ok, 2 = Low, 3 = High
		13..12	ISB	0 = Off, 1 = Ok, 2 = Low, 3 = High
		11..10	ISP	0 = Off, 1 = Ok, 2 = Low, 3 = High
		9..8	IRP1	0 = Off, 1 = Ok, 2 = Low, 3 = High
		7..6	IRP2	0 = Off, 1 = Ok, 2 = Low, 3 = High
		5..4	ERP	0 = Off, 1 = Ok, 2 = Low, 3 = High
		3..2	FIL 1 Bias	0 = Off, 1 = Ok, 2 = Low, 3 = High
		1..0	FIL 2 Bias	0 = Off, 1 = Ok, 2 = Low, 3 = High
004	2		Voltage flags 2	
		15..14	FIL 1 Emi	0 = Off, 1 = Ok, 2 = Low, 3 = High
		13..12	FIL 1 Cur	0 = Off, 1 = Ok, 2 = Low, 3 = High
		11..10	FIL 2 Emi	0 = Off, 1 = Ok, 2 = Low, 3 = High
		9..8	FIL 2 Cur	0 = Off, 1 = Ok, 2 = Low, 3 = High
		7..6	SLL	0 = Off, 1 = Ok, 2 = Low, 3 = High
		5..4	SLR	0 = Off, 1 = Ok, 2 = Low, 3 = High
		3..2	SES	0 = Off, 1 = Ok, 2 = Low, 3 = High



Rosetta Rosina

Reference : **RO-ROS-Man-1007**
 Issue : **3** Rev. : **0**
 Date : 26.04.19
 Section : 6 Page : **121**

		1..0	SEB	0 = Off, 1 = Ok, 2 = Low, 3 = High
006	2		Voltage flags 3	
		15..14	TLL	0 = Off, 1 = Ok, 2 = Low, 3 = High
		13..12	TLR	0 = Off, 1 = Ok, 2 = Low, 3 = High
		11..10	VACC Dac	0 = Off, 1 = Ok, 2 = Low, 3 = High
		9..8	ESS1 Dac	0 = Off, 1 = Ok, 2 = Low, 3 = High
		7..6	ESS2 Dac	0 = Off, 1 = Ok, 2 = Low, 3 = High
		5..4	RQ Dac	0 = Off, 1 = Ok, 2 = Low, 3 = High
		3..2	ESA C Dac	0 = Off, 1 = Ok, 2 = Low, 3 = High
		1..0	ESAO Dac	0 = Off, 1 = Ok, 2 = Low, 3 = High
008	2		Voltage flags 4	
		15..14	ESAI Dac	0 = Off, 1 = Ok, 2 = Low, 3 = High
		13..12	MP Dac	0 = Off, 1 = Ok, 2 = Low, 3 = High
		11..10	HP Dac	0 = Off, 1 = Ok, 2 = Low, 3 = High
		9..8	Z1Q Dac	0 = Off, 1 = Ok, 2 = Low, 3 = High
		7..6	Z2Q Dac	0 = Off, 1 = Ok, 2 = Low, 3 = High
		5..4	CEM REP Dac	0 = Off, 1 = Ok, 2 = Low, 3 = High
		3..2	CEM HV Dac	0 = Off, 1 = Ok, 2 = Low, 3 = High
		1..0	CEM THR Dac	0 = Off, 1 = Ok, 2 = Low, 3 = High
010	2		Voltage flags 5	
		15..14	CEM Cur	0 = Off, 1 = Ok, 2 = Low, 3 = High
		13..12	MCP Front	0 = Off, 1 = Ok, 2 = Low, 3 = High
		11..10	MCP Back1	0 = Off, 1 = Ok, 2 = Low, 3 = High
		9..8	MCP Back2	0 = Off, 1 = Ok, 2 = Low, 3 = High
		7..6	FDP REP Ena	0 = Off, 1 = Ok, 2 = Low, 3 = High
		5..4	Spare	0 = Off, 1 = Ok, 2 = Low, 3 = High
		3..2	Spare	0 = Off, 1 = Ok, 2 = Low, 3 = High
		1..0	Spare	0 = Off, 1 = Ok, 2 = Low, 3 = High
012	2		MAG Temp	°C = (value * -1.2048e-2) + 26.6
014	2		Spare	

6.2.4.2 RTOF Science HK Data, Length 123 words

Position	Bytes	Bits	Name	Data
000	1		RTOF Science HK Header	0xC8
001	1		Spare	
002	2		Status Bits 1	
		15	PSU 9kV	0 = Off, 1 = On
		14	PSU 70V	0 = Off, 1 = On
		13	PSU Ion MCP	0 = Off, 1 = On
		12	PSU Gas MCP	0 = Off, 1 = On
		11	PSU HM Power	0 = Off, 1 = On
		10	PSU Pulser	0 = Off, 1 = On
		9	ETSL Ram Test Active	0 = Off, 1 = On
		8	ETSL Ram Test Status	0 = Off, 1 = On



Rosetta Rosina

Reference : **RO-ROS-Man-1007**

Issue : **3** Rev. : **0**

Date : 26.04.19

Section : 6 Page : **122**

		7	ETSL Ram Test Data	Dec value
		6	ETS Ram Test Active	0 = Off, 1 = On
		5	ETS Ram Test Status	0 = Off, 1 = On
		4	ETS Ram Test Data	Dec value
		3..0	Spare	
004	2		ETS/L Lower Read Address	Hex value
006	2		ETS/L Upper Read Address	Hex value
008	2		Status Bits 2	
		15..1 3	Spare	
		12	ETSL Lower Range	0 = Off, 1 = On
		11	ETSL Upper Range	0 = Off, 1 = On
		10	FEC Fil 2 Gas	0 = Off, 1 = On
		9	FEC Fil 1 Gas	0 = Off, 1 = On
		8	FEC Fil 2 Ion	0 = Off, 1 = On
		7	FEC Fil 1 Ion	0 = Off, 1 = On
		6	FEC I Status	0 = Ion, 1 = Gas
		5	FEC EH Ion	0 = Off, 1 = On
		4	FEC EH Gas	0 = Off, 1 = On
		3	ETS/L LRA Bit 16	Hex value
		2	ETS/L URA Bit 16	Hex value
		1	ETS Lower Range	0 = Off, 1 = On
		0	ETS Upper Range	0 = Off, 1 = On
010	2		MC_FEC_ION_FIHEAT_I	I=value* 0.2651 [mA]
012	2		MC_FEC_GAS_FIHEAT_I	I = value * 0.2013 [mA]
014	2		MC_FEC_ION_REP_V_#A	V = value * -0.0371 -0.0894
016	2		MC_FEC_ION_REP_V_#B	V = value * -0.037 -0.1574
018	2		MC_FEC_GAS_REP_V_#A	V = value * -0.0371 -0.271
020	2		MC_FEC_GAS_REP_V_#B	V = value * -0.0372 -0.2382
022	2		MC_FEC_ION_FIL_V	V = value * 0.0327 -176.02
024	2		MC_FEC_GAS_FIL_V	V = value * 0.0313 -168.53
026	2		MC_FEC_GAS_FIL_I	I = value *0.0852 -0.6257 [uA]
028	2		MC_FEC_ION_ENT1_V	V = value * 0.0133 -54.068
030	2		MC_FEC_ION_ENT1_I	I = value * 0.0851 + 0.133 [uA]
032	2		MC_FEC_GAS_TRAP_V	V = value * -0.0149 + 0.0486
034	2		MC_FEC_HVVG_V	U = value * 5.1e-3 -0.0256 [V]
036	2		MC_FEC_HEAT_VG_V	U = value * 5.1e-3 -0.0257 [V]
038	2		MC_FEC_TEMP	T = value * 0.060 - 273 [°C]
040	2		MC_GEX_TEMP	V = (value * 366e-6)
042	2		MC_HM_PW	V = (value * 0.0037) -0.4095
044	2		MC_HM_DEL	V = (value * 0.0037) -0.2594
046	2		MC_HM_TEMP	V = (value * 366e-6)
048	2		MC Power State 2	
		15	ETSL VDD On	0 = Off, 1 = On
		14	ETSL VDD Off	0 = Off, 1 = On
		13	ETSL VCC On	0 = Off, 1 = On



Rosetta Rosina

Reference : **RO-ROS-Man-1007**

Issue : **3** Rev. : **0**

Date : 26.04.19

Section : 6 Page : **123**

		12	ETSL VCC Off	0 = Off, 1 = On
		11	Heater Gas On	0 = Off, 1 = On
		10	Heater Gas Off	0 = Off, 1 = On
		9	Heater Ion On	0 = Off, 1 = On
		8	Heater Ion Off	0 = Off, 1 = On
		7	Motor Hall Enable	0 = Off, 1 = On
		6	Motor Hall Disable	0 = Off, 1 = On
		5	Motor Direction Open	0 = Off, 1 = On
		4	Motor Direction Close	0 = Off, 1 = On
		3	Motor Power On	0 = Off, 1 = On
		2	Motor Power Off	0 = Off, 1 = On
		1	Motor High Torque On	0 = Off, 1 = On
		0	Motor High Torque Off	0 = Off, 1 = On
050	2		MC Pulser State	
		15	Gas Pulser On	0 = Off, 1 = On
		14	Gas Pulser Off	0 = Off, 1 = On
		13	HM Pulser On	0 = Off, 1 = On
		12	HM Pulser Off	0 = Off, 1 = On
		11	Ion Pulser On	0 = Off, 1 = On
		10	Ion Pulser Off	0 = Off, 1 = On
		9..0	Spare	
052	2		MC Power State 6	
		15..1	Spare	
		0		
		9	Disable ETS LU	0 = Off, 1 = On
		8	Enable ETS LU	0 = Off, 1 = On
		7	ETS VCA On	0 = Off, 1 = On
		6	ETS VCA Off	0 = Off, 1 = On
		5	ETS VDD On	0 = Off, 1 = On
		4	ETS VDD Off	0 = Off, 1 = On
		3	ETS VCC On	0 = Off, 1 = On
		2	ETS VCC Off	0 = Off, 1 = On
		1	ETS VSH/VE On	0 = Off, 1 = On
		0	ETS VSH/VE Off	0 = Off, 1 = On
054	2		MC Power State 8	
		15	GCU 1 On	0 = Off, 1 = On
		14	GCU 1 Off	0 = Off, 1 = On
		13	GCU 2 On	0 = Off, 1 = On
		12	GCU 2 Off	0 = Off, 1 = On
		11	GCU 1 Valve On	0 = Off, 1 = On
		10	GCU 1 Valve Off	0 = Off, 1 = On
		9	GCU 2 Valve On	0 = Off, 1 = On
		8	GCU 2 Valve Off	0 = Off, 1 = On
		7	FEC VCC On	0 = Off, 1 = On
		6	FEC VCC Off	0 = Off, 1 = On
		5	FEC VDD On	0 = Off, 1 = On



Rosetta Rosina

Reference : **RO-ROS-Man-1007**

Issue : **3** Rev. : **0**

Date : 26.04.19

Section : 6 Page : **124**

		4	FEC VDD Off	0 = Off, 1 = On
		3	FEC Heater VG On	0 = Off, 1 = On
		2	FEC Heater VG Off	0 = Off, 1 = On
		1	FEC HV VG On	0 = Off, 1 = On
		0	FEC HV VG Off	0 = Off, 1 = On
056	2		MC_ETSL_TEMP	$V = (\text{value} * 366\text{e-}6)$
058	2		MC_ETS_TEMP_CLK	$V = (\text{value} * 366\text{e-}6)$
060	2		MC_ETS_TEMP_DIG	$V = (\text{value} * 366\text{e-}6)$
062	2		PSDC_ELB_I	$V = (\text{value} * -0.0062)$
064	2		PSDC_ELA_I	$V = (\text{value} * -0.0062)$
066	2		PSDC_GR_I	$V = (\text{value} * -0.0062)$
068	2		PSDC_BP_I	$V = (\text{value} * -0.0062)$
070	2		PSDC_GR_G	$V = (\text{value} * -0.00619)$
072	2		PSDC_BP_G	$V = (\text{value} * -0.0062)$
074	2		HV1_SL_G	$V = (\text{value} * -1.0271) + 110.5$
076	2		HV1_A2_G	$V = (\text{value} * -0.506) + 42.568$
078	2		HV1_A1_G	$V = (\text{value} * -0.2561) + 48.511$
080	2		HV1_SL_I	$V = (\text{value} * -1.0122) + 44.499$
082	2		HV1_A2_I	$V = (\text{value} * -0.5089) + 35.088$
084	2		HV1_A1_I	$V = (\text{value} * -0.2566) + 20.022$
086	2		HV2_P_G	$V = (\text{value} * -0.1258) + 2.7606$
088	2		HV2_P_I	$V = (\text{value} * -0.1261) + 5.0041$
090	2		HV1_D	$V = (\text{value} * -0.5088) + 31.123$
092	2		HV2_HM3	$V = (\text{value} * -0.1294) - 1.2232$
094	2		HV1_R1	$V = (\text{value} * -0.1268) + 3.0101$
096	2		HV1_R2	$V = (\text{value} * 0.2765) - 2175.6$
098	2		HV1_RL	$V = (\text{value} * 0.5594) - 4371.5-$
100	2		HV1_HM1	$V = (\text{value} * 0.2777) - 2156.2$
102	2		HV2_HM2	$V = (\text{value} * 0.0393) + 308.38$
104	2		HV1_HML	$V = (\text{value} * 0.5207) - 4123$
106	2		HV2_M_I	$V = (\text{value} * -0.7818) - 14.283$
108	2		HV2_M_G	$V = (\text{value} * -0.7695) + 47.787$
110	2		PSDC_E2_I	$V = (\text{value} * -0.0062)$
112	2		PSDC_Temp_BP_I	TBD
114	2		PSDC_Temp_BP_G	$T = (\text{value} * -1.831\text{e-}2) - 50 \text{ [}^\circ\text{C]}$
116	2		PSU_Temp_MCP_I	TBD
118	2		PSU_Temp_MCP_G	TBD
120	2		PSU_Temp_HV1	$T = (\text{value} * -0.0089) - 9 \text{ [}^\circ\text{C]}$
122	2		PSU_Temp_LVPS	$T = (\text{value} * -0.0089) - 9 \text{ [}^\circ\text{C]}$
124	2		ETSL Status 1	
		15	ETSL Ion Pulser Status	0 = Off, 1 = On
		14	ETSL Gas Pulser Status	0 = Off, 1 = On
		13	ETSL Sync Status	0 = Int, 1 = Ext
		12	ETSL Calib. Trigger Status	0 = Off, 1 = On
		11	ETSL Data Readout Status	0 = Off, 1 = On



Rosetta Rosina

Reference : **RO-ROS-Man-1007**

Issue : **3** Rev. : **0**

Date : 26.04.19

Section : 6 Page : **125**

		10	ETSL Acquisition Status	0 = Off, 1 = On
		9	ETSL DTS Status Cancel	0 = Event, 1 = Extraction
		8	ETSL DTS Status	0 = Off, 1 = On
		7.6	ETSL Input Status	0 = Ion, 1 = Calibrator, 2 = Gas, 3 = Gas
		5	ETSL Cal. Power Status	0 = Off, 1 = On
		4	ETSL ADC HIRM Status	0 = Off, 1 = On
		3	ETSL RAM Threshold	0 = Low, 1 = High
		2	ETSL FIFO Threshold	0 = Low, 1 = High
		1	ETSL Latchup Enabled	1 = Off, 0 = On
		0	ETSL Latchup Detected	0 = Off, 1 = On
126	1		ETSL Status 2	
		7	ETSL ADC Power Status	0 = Off, 1 = On
		6	ETSL ADC Threshold	0 = High, 1 = Low
		5.4	ETSL ML Mode	0 = Adapt, 1 = ML31, 2 = ML63, 3 = ML255
		3.0	Spare	
	1		ETSL Threshold Level	0 = 5.5mV, 1= 8mV, 2 = 12mV, 3 = 16.7mV, 4 = 20mV, 5= 23.4mV, 6 = 26.6mV, 7 = 33.4mV
128	2		ETSL Extraction Delay	$t = (\text{Value} * 26.5\text{ns}) + 158.5$
130	2		ETSL ToF	$t = (\text{Value} * 26.5\text{ns}) + 26.5$
132	2		ETSL Cal. Start Delay	$t = (\text{Value} * 26.5\text{ns}) + 26.5 + 141$
134	2		ETSL Cal. Pulse Height	$V = (\text{value} * 2.266 \text{ mV}) + 3.3659 \text{ mV}$
136	2		ETSL Cal. Pulse Width	$t = (\text{value} * 1.44 \text{ ns}) - 112.47 \text{ ns}$
138	2		ETS Status 1	
		15	ETS Ion Pulser Status	0 = Off, 1 = On
		14	ETS Gas Pulser Status	0 = Off, 1 = On
		13	ETS Synchronization Status	0 = Int, 1 = Ext
		12	ETS Calib. Trigger Status	0 = Off, 1 = On
		11	ETS Data Readout Status	0 = Off, 1 = On
		10	ETS Acquisition Status	0 = Off, 1 = On
		9	ETS DTS Status Cancel	0 = Event, 1 = Extraction
		8	ETS DTS Status	0 = Off, 1 = On
		7.6	ETS Input Status	0 = Ion, 1 = Calibrator, 2 = Gas, 3 = Gas
		5	ETS Cal. Power Status	0 = Off, 1 = On
		4	ETS ADC HIRM Status	0 = Off, 1 = On
		3	ETS RAM Threshold	0 = Low, 1 = High
		2	ETS FIFO Threshold	0 = Low, 1 = High
		1	ETS Latchup Enabled	1 = Off, 0 = On
		0	ETS Latchup Detected	0 = Off, 1 = On
140	1		ETS Status 2	
		7	ETS ADC Power Status	0 = Off, 1 = On
		6	ETS ADC Threshold	0 = High, 1 = Low
		5.4	ETS ML Mode	0 = Adapt, 1 = ML31, 2 = ML63, 3 = ML255



Rosetta Rosina

Reference : **RO-ROS-Man-1007**

Issue : **3** Rev. : **0**

Date : 26.04.19

Section : 6 Page : **126**

		3..0	Spare	
	1		ETS Threshold Level	0 = 5.5mV, 1= 8mV, 2 = 12mV, 3 = 16.7mV, 4 = 20mV, 5= 23.4mV, 6 = 26.6mV, 7 = 33.4mV
142	2		ETS Extraction Delay	$t = (\text{Value} * 26.5\text{ns}) + 158.5$
144	2		ETS ToF	$t = (\text{Value} * 26.5\text{ns}) + 26.5$
146	2		ETS Cal. Start Delay	$t = (\text{Value} * 26.5\text{ns}) + 26.5 + 141$
148	2		ETS Cal. Pulse Height	$V = (\text{value} * 2.314 \text{ mV}) + 4.928 \text{ mV}$
150	2		ETS Cal. Pulse Width	$t = (\text{value} * 1.2615 \text{ ns}) - 51.728 \text{ ns}$
152	2		MC_FEC_PVCC_V	$U = \text{value} * 1\text{e-}3 - 0.0156 \text{ [V]}$
154	2		MC_FEC_MVCC_V	$U = \text{value} * -7\text{e-}4 + 0.003 \text{ [V]}$
156	2		MC_FEC_PVDD_V	$U = \text{value} * 3.1\text{e-}3 + 0.0497 \text{ [V]}$
158	2		MC_FEC_MVDD_V	$U = \text{value} * -2.8\text{e-}3 + 0.1508 \text{ [V]}$
160	2		MC_GEX_PVCC	$V = (\text{value} * 0.001) - 0.0058$
162	2		MC_GEX_VD	$V = \text{value} * 0.0083 - 0.0417 \text{ [V]}$
164	2		MC_IEX_PVCC	$V = (\text{value} * 0.001) - 0.0058$
166	2		MC_IEX_VD	$V = \text{value} * 0.0083 - 0.0417 \text{ [V]}$
168	2		MC_HM_PVCA	$V = (\text{value} * 0.001) - 0.0038$
170	2		MC_HM_VD	$V = (\text{value} * 0.0083) - 0.0478$
172	2		MC_ETSL_PVCC	$V = (\text{value} * 0.0011) - 0.467$
174	2		MC_ETSL_MVCA	$V = (\text{value} * -7\text{e-}4) + 6.1\text{e-}3$
176	2		MC_ETSL_PVDD	$V = (\text{value} * 3.1\text{e-}3) - 1.26\text{e-}2$
178	2		MC_ETSL_MVDD	$V = (\text{value} * -2.8\text{e-}3) + 6.8\text{e-}3$
180	2		MC_HEAT_ION_VG	$V = (\text{value} * 0.0051) - 0.036$
182	2		MC_HEAT_GAS_VG	$V = (\text{value} * 0.0052) - 0.0362$
184	2		MC_ETS_33V	$V = (\text{value} * 366\text{e-}6)$
186	2		MC_ETS_PVCA	$V = (\text{value} * 366\text{e-}6)$
188	2		MC_ETS_MVCA	$V = (\text{value} * 366\text{e-}6)$
190	2		MC_ETS_VE	$V = \text{value} * 0.0014 - 0.001 \text{ [V]}$
192	2		MC_ETS_PVDD	$V = \text{value} * 0.0031 - 0.0093 \text{ [V]}$
194	2		MC_ETS_MVDD	$V = \text{value} * -0.0032 + 0.1103 \text{ [V]}$
196	2		MC_ETS_VSH	$V = \text{value} * 0.0096 + 0.0747 \text{ [V]}$
198	2		MC_ETSL_PVCA	$V = (\text{value} * 1.1\text{e-}3) - 0.467$
200	2		PSU_+5_Val	$V = (\text{value} * -0.001488)$
202	2		PSU_-5_Val	$V = (\text{value} * -0.001428)$
204	2		PSU_+15_Val	$V = (\text{value} * -0.00458)$
206	2		PSU_-15_Val	$V = (\text{value} * -0.004415)$
208	2		PSU_+24_Val	$V = (\text{value} * -0.006954)$
210	2		PSU_+8_Val	$V = (\text{value} * -0.0014792)$
212	2		PSU_+5_Add_Val	$V = (\text{value} * -0.0014798)$
214	2		PSU_+40_Val	$V = (\text{value} * -0.0174) - 0.4234$
216	2		PSU_+70_Val	$V = (\text{value} * -0.0107) + 4.173$
218	2		PSU_+5_Cur	$I = \text{value} * -0.4383 + 30 \text{ [mA]}$
220	2		PSU_-5_Cur	$I = \text{value} * -0.1508 - 28.016 \text{ [mA]}$
222	2		PSU_+15_Cur	$I = \text{value} * -0.1133 - 16.502 \text{ [mA]}$
224	2		PSU_-15_Cur	$I = \text{value} * -0.0553 - 24.715 \text{ [mA]}$



226	2		PSU_+24_Cur	$I = \text{value} * -0.1285 + 33.042$ [mA]
228	2		PSU_+40/70_Cur	$I = \text{value} * -0.0174 - 0.4234$ [mA]
230	2		PSU_+5_Add_Cur	$I = \text{value} * -0.0571 + 3.4918$ [mA]
232	2		PSU_+8_Cur	$I = \text{value} * -0.0254 + 5.663$ [mA]
234	4		ETSL NOE	
		31..2 5	Spare	
		24..1 7	NOE High value	Dec value
		16..9	Spare	
		8..1	NOE Low value	Dec value
		0	NOE Status	0 = Continuous, 1 = NOE
238	2		ETS NOE High	
		15..9	Spare	
		8..1	NOE High value	Dec value
240	2		ETS NOE Low	
		15..9	Spare	
		8..1	NOE Low value	Dec value
		0	NOE Status	0 = Continuous, 1 = NOE
242	2		Spare 1	
244	2		Spare 2	

6.2.4.3 COPS Science HK Data, Length 10 words

Position	Bytes	Bits	Name	Data
000	1		COPS Science HK Header	0xCC
001	3		Spare	
004	4		Pressure NG	Pressure in mbar, floating point
008	4		Pressure RG	Pressure in mbar, floating point
012	4		Calib. factor / Offset NG	Floating point value
016	4		Calib. factor / Offset RG	Floating point value
018	2		Active Filament/Microtips	
		15..8	Microtips Array	MT 8..1: 0 = On, 1 = Off
		7..6	DPU MT Ion Range	0 = Low, 1 = Medium, 2 = High
		5	DPU MT Emission Range	0 = Low, 1 = High
		4	Filament	0 = Left, 1 = Right
		3..2	DPU Fil Ion Range	0 = Low, 1 = Medium, 2 = High
		1	DPU Fil. Emission Range	0 = Low, 1 = High
		0	DPU Function	0 = NG, 1 = RG



6.3 Event Packet Definitions

6.3.1 Packet Types and EIDs

Sub Type	EID	RSDB	Packet Size (words)	Description
1	44001	YRNG3001	9	Power-On self test report
1	44002	YRNG3002	10	Program memory test report
1	44003	YRNG3003	10	Data memory test report
1	44004	YRNG3004	10	EEPROM test report (ground test only)
1	44005	YRNG3005	12	Operation mode change report
1	44006	YRNG3006	17	Sensor switch-on report
1	44007	YRNG3010	10	Progress report
1	44008	YRNG3011	28	Table Setting report
2	44100	YRNG3007	7	DPU latch-up report
2	44101	YRNG3008	13	DPU memory error report
2	44102	YRNG3009	11	DPU general error report
2	44103	YRNG300A	14	Sensor I/F error report
2	44104	YRNG300B	11	Sensor error report
3				
4	44300	YRNG300C	3	COPS Pressure Alert
4	44301	YRNG300D	2	Switch-Off Ready Alert

6.3.2 Normal Event Packet Definitions, Sub Type 1

6.3.2.1 POST Report, EID = 44001, Length 9 words

Pos	RSDB	Byte	Bit	Name	Data
000	NRNAG304	2		EID	44001
002	NRNAG305	1		Unit	208
003		1		Spare	0
004	NRNAG307	4		Error Code	Hex value
008	NRNAG308	4		Error Position / Address	Hex value / Boot Err Cnt PM/DM
012	NRNAG306	1		DPU Self test status	
			7	Processor self test	0 = Ok, 1 = Error
			6	PM self test	0 = Ok, 1 = Error



Rosetta Rosina

Reference : **RO-ROS-Man-1007**

Issue : **3** Rev. : **0**

Date : 26.04.19

Section : 6 Page : **129**

			5	EEPROM self test	0 = Ok, 1 = Error
			4	SRAM 1 self test	0 = Ok, 1 = Error
			3	SRAM 2 self test	0 = Ok, 1 = Error
			2	Stat EEPROM self test	0 = Ok, 1 = Error
			1..0	Sensor I/F self test	0 = Ok, 1 = DFMS Error, 2 = RTOF Error, 3 = COPS Error
013		1		DPU Status	
			7	DPU power save	0 = Off, 1 = On
			6	LU detect	0 = Off, 1 = On
			5	Boot Err PM	0 = Off, 1 = On
			4	Boot Err DM	0 = Off, 1 = On
			3..0	Spare	
014	NRNAG309	2		DPU power status	
			15	Spare	
			14	Status SRAM 2	0 = Off, 1 = On
			13	Status SRAM 1	0 = Off, 1 = On
			12	Status Stat EEPROM	0 = Off, 1 = On
			11	Status I/F COPS	0 = Off, 1 = On
			10	Status I/F RTOF	0 = Off, 1 = On
			9	Status I/F DFMS	0 = Off, 1 = On
			8	Status EEPROM	0 = Off, 1 = On
			7	Sensitivity DSP	0 = Low, 1 = High
			6	Sensitivity SRAM 2	0 = Low, 1 = High
			5	Sensitivity SRAM 1	0 = Low, 1 = High
			4	Sensitivity Stat EEPROM	0 = Low, 1 = High
			3	Sensitivity I/F COPS	0 = Low, 1 = High
			2	Sensitivity I/F RTOF	0 = Low, 1 = High
			1	Sensitivity I/F DFMS	0 = Low, 1 = High
			0	Sensitivity EEPROM	0 = Low, 1 = High
016	NRNAG30A	2		DPU S/W status	Hex value



6.3.2.2 PM Test Report, EID = 44002, Length 10 words

Pos	RSDB	Byte	Bit	Name	Data
000	NRNAG304	2		EID	44002
002	NRNAG30C	2		Spare	0
004		1		Unit	208
005		1		Type	Hex value
006	NRNAG30D	1		Symbol	Hex value
007		1		Value	Hex value
008	NRNAG30E	4		Correct Data high	Hex value
012		2		Correct Data low	Hex value
014	NRNAG30F	4		Read Data high	Hex value
018		2		Read Data low	Hex value

6.3.2.3 DM Test Report, EID = 44003, Length 10 words

Pos	RSDB	Byte	Bit	Name	Data
000	NRNAG304	2		EID	44003
002	NRNAG30C	2		Spare	0
004		1		Unit	208
005		1		Type	Hex value
006	NRNAG30D	1		Symbol	Hex value
007		1		Value	Hex value
008	NRNAG30E	4		Correct Data high	Hex value
012		2		Correct Data low	Hex value
014	NRNAG30F	4		Read Data high	Hex value
018		2		Read Data low	Hex value

6.3.2.4 EEPROM Test Report, EID = 44004, Length 10 words

Pos	RSDB	Byte	Bit	Name	Data
000	NRNAG304	2		EID	44004
002	NRNAG316	2		Spare	0
004		1		Unit	208
005		3		Address	Hex value
008	NRNAG30E	4		Correct Data high	Hex value
012		2		Correct Data low	Hex value
014	NRNAG30F	4		Read Data high	Hex value
018		2		Read Data low	Hex value



6.3.2.5 Operation Mode Change Report, EID = 44005, Length 12 words

Pos	RSDB	Byte	Bit	Name	Data
000	NRNAG304	2		EID	44005
002	NRNAG305	1		Unit	208
003		1		Spare	0
004	NRNAG31B	2		DPU Mode	Hex value
006	NRNAG3A0	2		DPU Status	Hex value
008	NRNAG31C	2		DFMS Mode	Hex value
010	NRNAG3A1	2		DFMS Status	Hex value
012	NRNAG31D	2		RTOF Mode	Hex value
014	NRNAG3A2	2		RTOF Status	Hex value
016	NRNAG31E	2		COPS Mode	Hex value
018	NRNAG3A3	2		COPS Status	Hex value
020	NRNAG31F	2		Mode Change ID	Hex value
022	NRNAG320	1		Active SID	Hex value
023		1		Spare	0

6.3.2.6 Sensor Switch-On Report, EID = 44006, Length 17 words

Pos	RSDB	Byte	Bit	Name	Data
000	NRNAG304	2		EID	44006
002	NRNAG322	1		Unit	196 = DFMS, 200 = RTOF, 204 = COPS
003		1		Flags	Hex value
004	NRNAG323	2		Power State 1	Hex value
006	NRNAG324	2		Power State 2	Hex value
008	NRNAG325	2		Power State 3	Hex value
010	NRNAG326	2		Voltage Value 1	$V = (\text{value} * X) + Y$
012	NRNAG327	2		Voltage Value 2	$V = (\text{value} * X) + Y$
014	NRNAG328	2		Voltage Value 3	$V = (\text{value} * X) + Y$
016	NRNAG329	2		Current Value 1	$A = (\text{value} * X) + Y$
018	NRNAG32A	2		Current Value 2	$A = (\text{value} * X) + Y$
020	NRNAG32B	2		Current Value 3	$A = (\text{value} * X) + Y$
022	NRNAG32C	2		Temperature Value 1	$^{\circ}\text{C} = (\text{value} * X) + Y$
024	NRNAG32D	2		Temperature Value 2	$^{\circ}\text{C} = (\text{value} * X) + Y$
026	NRNAG32E	2		Unit Mode	Hex value
028	NRNAG3A4	2		Unit Status	Hex value
030	NRNAG32F	2		Mode Change ID	Hex value
032	NRNAG330	2		Spare	0



6.3.2.7 Progress Report, EID = 44007, Length 10 words

Pos	RSDB	Byte	Bit	Name	Data
000	NRNAG304	2		EID	44007
002	NRNAG322	1		Unit	196 = DFMS, 200 = RTOF, 204 = COPS, 208 = DPU
003		1		Flags	Hex value
004	NRNAG3A5	2		Progress No.	Hex value
006	NRNAG3A6	2		Progress Code	Hex value
008	NRNAG3A7	4		Progress Position / Address	Hex value
012	NRNAG3A8	2		Command counter	Counter 0..65535
014	NRNAG32E	2		Unit Mode	Hex value
016	NRNAG3A4	2		Unit Status	Hex value
018	NRNAG330	2		Spare	0

6.3.2.8 Table Setting Report, EID = 44008, Length 28 words

Pos	RSDB	Byte	Bit	Name	Description
000	NRNAG304	2		EID	44008
002	NRNAG3A9	1		Unit	196 = DFMS, 200 = RTOF, 204 = COPS, 208 = DPU
003		1		Type	type of table
004	NRNAG3AA	2		Table No.	pointer to table
006	NRNAG3AB	2		Entry No.	pointer to parameter entry
008	NRNAG3AC	2		Function/Shift	function no. / shift parameter
010	NRNAG3AD	2		Mask	and mask
012	NRNAG3AE	4		Default	or mask
016	NRNAG3AF	4		Parameter Value 1	multiplier (floating point)
020	NRNAG3B0	4		Parameter Value 2	offset (floating point)
024	NRNAG3B1	2		Monitoring	monitoring function no.
026	NRNAG3B2	2		Wait	wait time for monitoring in ms
028	NRNAG3B3	4		Parameter Value 3	step width (floating point)
032	NRNAG3B4	4		Parameter Value 4	limit (floating point)
036	NRNAG3B5	4		Parameter Value 5	sleep time in ms
040	NRNAG3B6	4		HK Cmd 1	sensor cmd for hk read
044	NRNAG3B7	4		HK Cmd 2	sensor cmd for hk read
048	NRNAG3B8	4		HK Cmd 3	sensor cmd for hk read
052	NRNAG3B9	4		HK Cmd 4	sensor cmd for hk read



6.3.3 Anomalous Event Packet Definitions, Sub Type 2

6.3.3.1 DPU Latch-up Report, EID = 44100, Length 7 words

Pos	RSDB	Byte	Bit	Name	Data
000	NRNAG304	2		EID	44100
002	NRNAG305	1		Unit	208
003		1		Spare	0
004	NRNAG333	2		Latch-up position	Hex value
006	NRNAG3BA	2		Latch-up counter	Counter
008	NRNAG309	2		DPU power status	
			15	Spare	
			14	Status SRAM 2	0 = Off, 1 = On
			13	Status SRAM 1	0 = Off, 1 = On
			12	Status Stat EEPROM	0 = Off, 1 = On
			11	Status I/F COPS	0 = Off, 1 = On
			10	Status I/F RTOF	0 = Off, 1 = On
			9	Status I/F DFMS	0 = Off, 1 = On
			8	Status EEPROM	0 = Off, 1 = On
			7	Sensitivity DSP	0 = Low, 1 = High
			6	Sensitivity SRAM 2	0 = Low, 1 = High
			5	Sensitivity SRAM 1	0 = Low, 1 = High
			4	Sensitivity Stat Eeprom	0 = Low, 1 = High
			3	Sensitivity I/F COPS	0 = Low, 1 = High
			2	Sensitivity I/F RTOF	0 = Low, 1 = High
			1	Sensitivity I/F DFMS	0 = Low, 1 = High
			0	Sensitivity EEPROM	0 = Low, 1 = High
010	NRNAG31B	2		DPU Mode	Hex value
012	NRNAG3A0	2		DPU Status	Hex value

6.3.3.2 DPU Memory Error Report, EID = 44101, Length 13 words

Pos	RSDB	Byte	Bit	Name	Data
000	NRNAG304	2		EID	44101
002	NRNAG305	1		Unit	208
003		1		Spare	0
004	NRNAG338	1		PM Error Count 1 Symbol	Counter
005		1		PM Error Count 2 Symbols	Counter
006	NRNAG339	2		PM Error status	Hex value
008	NRNAG33A	4		PM Error address	Hex value
012	NRNAG33B	1		DM Error Count 1 Symbol	Counter
013		1		DM Error Count 2 Symbols	Counter
014	NRNAG33C	2		DM Error status	Hex value
016	NRNAG33D	4		DM Error address	Hex value
020	NRNAG3BB	1		EEPROM Error Count 1	Counter 0..255, 0xFF for Boot
021		1		EEPROM Error Count 2	Counter 0..255, 0xFF for Boot



022	NRNAG31B	2		DPU Mode / Boot CRC Cnt	Hex value
024	NRNAG3A0	2		DPU Status	Hex value

6.3.3.3 DPU General Error Report, EID = 44102, Length 11 words

Pos	RSDB	Byte	Bit	Name	Data
000	NRNAG304	2		EID	44102
002	NRNAG305	1		Unit	196 = DFMS, 200 = RTOF, 204 = COPS, 208 = DPU
003		1		Spare	0
004	NRNAG307	4		Error Code	Hex value
008	NRNAG308	4		Error Position / Address	Hex value
012	NRNAG3A8	2		Cmd/HK counter	Counter 0..65535
014	NRNAG345	1		DPU Processor load	1..100 Percent
015		1		Used memory PM	1..100 Percent
016	NRNAG346	1		Used memory DM	1..100 Percent
017		1		Spare	0
018	NRNAG31B	2		DPU Mode	Hex value
020	NRNAG3A0	2		DPU Status	Hex value

6.3.3.4 Sensor I/F Error Report, EID = 44103, Length 14 words

Pos	RSDB	Byte	Bit	Name	Data
000	NRNAG304	2		EID	44103
002	NRNAG322	1		Unit	196 = DFMS, 200 = RTOF, 204 = COPS
003		1		Flags	Hex value
004	NRNAG34A	2		Sensor HK & power status	
			15	COPS HK Status	0 = Off, 1 = On
			14	RTOF HK Status	0 = Off, 1 = On
			13	DFMS HK Status	0 = Off, 1 = On
			12..9	Spare	
			8	COPS Transc. Enable	0 = Disabled, 1 = Enabled
			7	COPS Main Power	0 = Off, 1 = On
			6	COPS Red. Power	0 = Off, 1 = On
			5	RTOF Transc. Enable	0 = Disabled, 1 = Enabled
			4	RTOF Main Power	0 = Off, 1 = On
			3	RTOF Red. Power	0 = Off, 1 = On
			2	DFMS Transc. Enable	0 = Disabled, 1 = Enabled
			1	DFMS Main Power	0 = Off, 1 = On
			0	DFMS Red. Power	0 = Off, 1 = On
006	NRNAG34B	2		Sensor HK counter	Counter 0..65535
008	NRNAG34C	2		Sensor Cmd counter	Counter 0..65535
010	NRNAG34D	2		Sensor Cmd Error counter	Counter 0..65535
012	NRNAG34E	2		Sensor Cmd Error position	Hex value
014	NRNAG34F	2		Sensor Science counter	Counter 0..65535



016	NRNAG350	2		Sensor Science Error cnt	Counter 0..65535
018	NRNAG351	2		Sensor Science Error pos	Hex value
020	NRNAG31B	2		DPU Mode	Hex value
022	NRNAG3A0	2		DPU Status	Hex value
024	NRNAG32E	2		Sensor Mode	Hex value
026	NRNAG3A4	2		Sensor Status	Hex value

6.3.3.5 Sensor Error Report, EID = 44104, Length 11 words

Pos	RSDB	Byte	Bit	Name	Data
000	NRNAG304	2		EID	44104
002	NRNAG322	1		Unit	196 = DFMS, 200 = RTOF, 204 = COPS
003		1		Flags	Hex value
004	NRNAG3BC	2		Error No.	Hex value
006	NRNAG356	2		Table ID	Hex value
008	NRNAG357	2		Limit ID	Hex value
010	NRNAG358	2		Value No.	Hex value
012	NRNAG359	2		Expected Value	Hex value
014	NRNAG35A	2		Read Value	Hex value
016	NRNAG32E	2		Sensor Mode	Hex value
018	NRNAG3A4	2		Sensor Status	Hex value
020	NRNAG330	2		Spare	0

6.3.4 Ground Action Event Packet Definitions, Sub Type 3

N/A

6.3.5 On-board Action Event Packet Definitions, Sub Type 4

6.3.5.1 COPS Pressure Alert, EID = 44300, Length 3 words

Pos	RSDB	Byte	Bit	Name	Data
000	NRNAG304	2		EID	44300
002	NRNAG305	1		Unit	204
003		1		Spare	0
004	NRNAG35F	1		COPS Pressure	mmmmeeee mbar
005		1		COPS Pressure Gradient	mmmmeeee mbar/s

6.3.5.2 Switch-Off Ready Alert, EID = 44301, Length 2 word

Pos	RSDB	Byte	Bit	Name	Data
000	NRNAG304	2		EID	44301



002	NRNAG305	1		Unit	208
003		1		Spare	0

6.4 Context File Definition

Context File (length 170 bytes)

Pos	Byte	Bit	Name	Data
000	2		Header	
002	2		Spare	
004	2		Number	
006	6		Time	
012	2		DPU Cmd counter	Counter 0..65535
014	2		DPU Cmd Error counter	Counter 0..65535
016	2		Latch-Up Counter	Counter 0..65535
018	1		PM Error Count 1	Counter 0..255
019	1		PM Error Count 2	Counter 0..255
020	1		DM Error Count 1	Counter 0..255
021	1		DM Error Count 2	Counter 0..255
022	1		EEPROM Error Count 1	Counter 0..255
023	1		EEPROM Error Count 2	Counter 0..255
024	2		DPU S/W mode	Mode No.
026	2		DPU S/W status	Hex value
028	2		DPU Last Mode	
030	2		DPU Abort Status	
032	2		Spare 1	
034	2		Spare 2	
036	2		DFMS Cmd counter	Counter 0..65535
038	2		DFMS Cmd Error cnt	Counter 0..65535
040	2		DFMS Science counter	Counter 0..65535
042	2		DFMS Science Error counter	Counter 0..65535
044	2		DFMS S/W mode	Mode No.
046	2		DFMS S/W status	Hex value
048	2		DFMS Motor Pos 1	
050	2		DFMS Motor Pos 2	
052	2		DFMS GCU 1 On Time	
054	2		DFMS GCU 2 On Time	
056	2		DFMS Filament Status	
058	2		DFMS Heater Status	
060	2		DFMS Last Mode	
062	2		DFMS Abort Status	
064	2		DFMS Last Scan Mode	



Rosetta Rosina

Reference : **RO-ROS-Man-1007**

Issue : **3** Rev. : **0**

Date : 26.04.19

Section : 6 Page : **137**

066	2		DFMS Last Sequence	
068	2		Sequence Position 1	
070	2		Sequence Position 2	
072	4		Sequence Parameter 1	
076	4		Sequence Parameter 2	
080	4		Sequence Parameter 3	
084	4		Sequence Parameter 4	
088	2		DFMS Spare 1	
090	2		DFMS Spare 2	
092	2		RTOF Cmd counter	Counter 0..65535
094	2		RTOF Cmd Error cnt	Counter 0..65535
096	2		RTOF Science counter	Counter 0..65535
098	2		RTOF Science Error counter	Counter 0..65535
100	2		RTOF S/W mode	Mode No.
102	2		RTOF S/W status	Hex value
104	2		RTOF Motor Pos 1	
106	2		RTOF Motor Pos 2	
108	2		RTOF GCU 1 On Time	
110	2		RTOF GCU 2 On Time	
112	2		RTOF Filament Status	
114	2		RTOF Heater Status	
116	2		RTOF Last Mode	
118	2		RTOF Abort Status	
120	2		RTOF Last Scan Mode	
122	2		RTOF Last Sequence	
124	2		Sequence Position 1	
126	2		Sequence Position 2	
128	4		Sequence Parameter 1	
132	4		Sequence Parameter 2	
136	4		Sequence Parameter 3	
140	4		Sequence Parameter 4	
144	2		RTOF Spare 1	
146	2		RTOF Spare 2	
148	2		COPS Cmd counter	Counter 0..65535
150	2		COPS Cmd Error counter	Counter 0..65535
152	2		COPS HK Error counter	Counter 0..65535
154	2		COPS S/W mode	Mode No.
156	2		COPS S/W status	Hex value
158	2		COPS Filament Status	
160	2		COPS Microtips Status	
162	2		COPS Monitoring Status	
164	2		COPS Last Mode	
166	2		COPS Abort Status	
168	2		COPS Spare	